

RES-5010

Operating instructions



Contents

1	General information	3	6	Device functions	17
1.1	Intended use	3	6.1	LEDs and controls	17
1.2	Heatsealing band	3	6.2	PROFINET communication	19
1.3	Impulse transformer	3	6.3	Device master file (GSDML)	19
1.4	Current transformer PEX-W2/-W3/-W4	3	6.4	Communication protocol	20
1.5	Line filter	4	6.5	Input data	20
1.6	Standards / CE marking	4	6.6	Output data	23
1.7	Maintenance	4	6.7	Parameter data	24
1.8	Disposal	4	6.8	Integrated web server	31
2	Application	4	6.9	Undervoltage detection	33
3	Principle	5	6.10	Temperature meter (actual value output)	33
4	Mounting and installation	6	6.11	Booster connection	34
4.1	Installation procedure	6	6.12	USB interface for visualization software (ROPEXvisual®)	34
4.2	Installation steps	7	6.13	AUX interface	35
4.3	Power supply	8	6.14	Total cycle counter	35
4.4	Line filter	9	6.15	Operating hours counter	35
4.5	Current transformer PEX-W3/-W4	9	6.16	Data memory for error messages and AUTOCAL	35
4.6	Wiring diagram (standard)	10	6.17	Built-in clock (date and time)	35
4.7	Wiring diagram with booster connection	11	6.18	System monitoring / alarm output	36
5	Startup and operation	12	6.19	Error messages	36
5.1	View of the device	12	6.20	Fault areas and causes	40
5.2	Device configuration	12	7	Factory settings	42
5.3	Replacing and burning in the heatsealing band	14	8	Technical data	43
5.4	Startup procedure	15	9	Dimensions	45
			10	Accessories and modifications	45
			10.1	Accessories	45
			10.2	Modifications (MODs)	46
			11	How to order	47
			12	Index	48

1 General information

This RESISTRON temperature controller is manufactured according to DIN EN 61010-1. In the course of its manufacture it passed through quality assurance, whereby it was subjected to extensive inspections and tests. As a result of this, the product left our factory in perfect condition.

The recommendations and warning notes contained in these operating instructions must be complied with, in order to guarantee safe operation.

The device can be operated within the limits indicated in the "Technical Data" without impairing its operational safety. Installation and maintenance may only be performed by technically trained, skilled persons who are familiar with the associated risks and warranty provisions.

1.1 Intended use

RESISTRON temperature controllers may only be used for heating and temperature control of heatsealing bands which are expressly approved for them, and providing the regulations, notes and warnings contained in these instructions are observed.

In case of non-observance or use contrary to the intended purpose, there is a risk that safety will be impaired or that the heatsealing band, electrical wiring, transformer etc. will overheat. This is the personal responsibility of the user.

1.2 Heatsealing band

The use of suitable heatsealing bands is a basic prerequisite for reliable and safe operation of the system.

The resistance of the heatsealing band which is used must have a positive minimum temperature coefficient in order to guarantee trouble-free operation of the RESISTRON temperature controller.

The temperature coefficient must be specified as follows:

$$TCR \geq 10 \times 10^{-4} \text{K}^{-1}$$

e.g. Alloy-20: TCR = 1100 ppm/K
NOEX: TCR = 3500 ppm/K

The RESISTRON temperature controller must be set and coded according to the temperature coefficient of the heatsealing band.

 **The use of incorrect alloys with a too low temperature coefficient and incorrect coding of the RESISTRON temperature controller leads to uncontrolled heating of the heatsealing band, which will ultimately burn out!**

The original heatsealing bands must be clearly identified by means of suitable markings as well as the connector geometry, length, or other means to ensure that replacement bands are identical.

1.3 Impulse transformer

A suitable impulse transformer is necessary in order to guarantee trouble-free operation of the control loop. This transformer must be designed according to VDE 0570 / EN 61558 (isolating transformer with reinforced insulation) and have a one section bobbin. When the impulse transformer is installed, suitable touch protection must be provided in accordance with the national installation regulations for electrical equipment. In addition to this, water, cleaning solutions and conductive fluids must be prevented from seeping into the transformer.

Incorrect installation of the impulse transformer impairs electrical safety.

1.4 Current transformer PEX-W2/-W3/-W4

The current transformer supplied with the RESISTRON temperature controller is an integral part of the control system.

Only the original ROPEX PEX-W2, PEX-W3 or PEX-W4 current transformer may be used. Other transformers may cause the equipment to malfunction.

The current transformer may only be operated if it is correctly connected to the RESISTRON temperature controller (see section "Startup and operation"). The relevant safety instructions contained in section "Power supply", must be observed. External monitoring modules can be used in order to additionally increase operating safety. They are not included in the scope of supply of the standard control system and are described in a separate document.

1.5 Line filter

The use of an original ROPEX line filter is mandatory in order to comply with the standards and provisions mentioned in section 1.6 "Standards / CE marking" on page 4. This device must be installed and connected according to the instructions contained in section "Power supply" as well as the separate documentation enclosed with the line filter.

1.6 Standards / CE marking

The controller described here complies with the following standards, provisions and directives:

DIN EN 61010-1:2001 (2014/35/EU)	Safety requirements for electrical equipment for measurement, control and laboratory use (low-voltage directive): pollution degree 2, protection class I, measurement category I (for U_R and I_R terminals)
DIN EN 60204-1 (2006/42/EG)	Electrical equipment of machines (machinery directive)
EN 55011:2009+A1:2010 EN 61000-3-2:2006-04+ A1:2009+A2:2009 EN 61000-3-3:2008 EN 61000-6-4:2007+ A1:2011 (2014/30/EU)	EMC genery emissions: Group 1, Class A
EN 61000-6-2:2005 (2014/30/EU)	EMC generic immunity: Class A (ESD, RFI, burst, surge) <u>Exception:</u> Line voltage interruption acc. to EN 61000-4-11 is not fulfilled (This leads to a designated error message of the controller)

Compliance with these standards and provisions is only guaranteed if original accessories and / or peripheral components approved by ROPEX are used. If not, then the equipment is operated on the user's own responsibility.

2 Application

This RESISTRON temperature controller is an integral part of the "5000" series, the key feature of which is its microprocessor technology. All RESISTRON temperature controllers are used to control the temperature of heating elements (heatsealing bands, beaded bands,

The CE marking on the controller confirms that the device itself complies with the above-mentioned standards.

It does not imply, however, that the overall system also fulfils these standards.

It is the responsibility of the machine manufacturer and of the user to verify the completely installed, wired and operationally ready system in the machine with regard to its conformity with the safety provisions and the EMC directive (see also section "Power supply"). If peripheral components (e.g. the transformer or the line filter) from other manufacturers are used, no functional guarantee can be provided by ROPEX.

1.7 Maintenance

The controller requires no special maintenance. Regular inspection and / or tightening of the terminals – including the terminals for the winding connections on the impulse transformer – is recommended. Dust deposits on the controller can be removed with dry compressed air.

1.8 Disposal

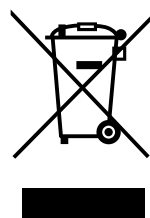

This device is subject to Directive 2012/19/EU concerning the reduction of the increasing amount of waste electrical and electronic equipment and the disposal of uch waste in an environmentally sound way.

It must not be disposed of as residual wase! To guarantee proper disposal and / or the recover of reusable material, please take the device to adesignated municipal collectin point and observe local regulations.

Careless, uncontrolled disposal can cause damage to the environment and human health. By ensuring that your product is disposed of or recycled in a responsible way, you can help protect the environment and human health.

cutting wires, heatsealing blades, solder elements etc.), as required in a variety of heatsealing processes. The controller is particularly used for impulse-heatsealing PE films in:

- Vertical and horizontal f/f/s machines

- Pouch, filling, and sealing machines
- Film wrapping machines
- Pouch making machines
- Group packaging machines
- L-sealers
- etc.

The use of RESISTRON temperature controllers enables:

- Repeatable heatseal quality under any conditions
- Increased machine capacity
- Extended life of the heatsealing bands and Teflon coatings
- Simple operation and control of the heatsealing process

3 Principle

The resistance of the heatsealing band, which is temperature sensitive, is monitored 50x per second (60x at 60 Hz) by measuring the current and voltage. The temperature calculated with the help of these measurements is indicated and compared with the set point.

The primary voltage of the impulse transformer is adjusted by phase-angle control if the measured values deviate from the set point. The resulting change in the current through the heatsealing band leads to a change in the band's temperature and thus also its resistance. This change is measured and evaluated by the RESISTRON temperature controller.

The control loop is thus closed: ACTUAL temperature = SET temperature. Even very small thermal loads on the heatsealing band are detected and can be corrected quickly and precisely.

A highly dynamic thermoelectric control loop is formed because purely electrical variables are measured at a high sampling rate. A very wide secondary current range can be controlled with only minimal power loss – a considerable advantage – because power is controlled on the primary side of the transformer. This

allows optimal adaptation to the load and to the required dynamics in spite of the controller's extremely compact dimensions.

Note:

RESISTRON temperature controllers play a significant role in enhancing the performance of modern machines. However, the full benefit can only be obtained from the control system's advanced technology if all of the system components – in other words the heatsealing band, impulse transformer, wiring, timing signals, and the controller itself – are fully compatible with one another.

We will be pleased to contribute our many years of experience towards optimizing *your* heatsealing system.

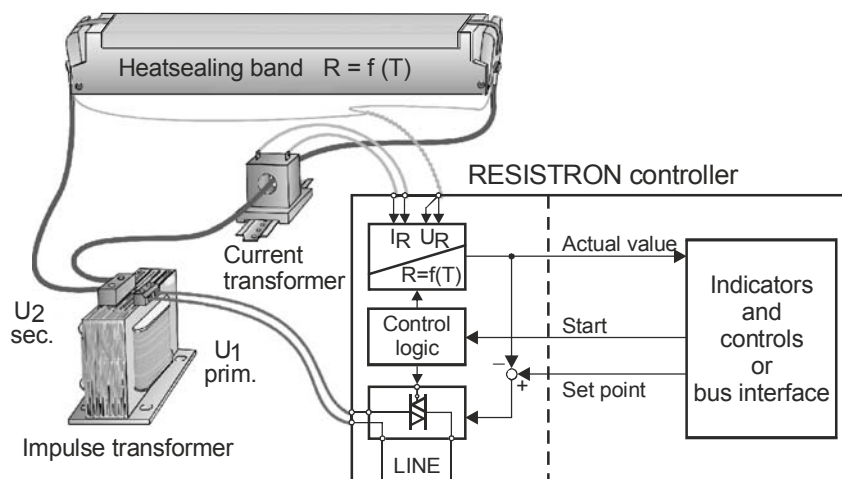

4 Mounting and installation

↪ See also section 1 "General information" on page 3.

 **Mounting, installation and startup may only be performed by authorized persons who have received suitable instruction and are familiar with the associated risks and warranty provisions.**

4.1 Installation procedure

Proceed as follows to install the RESISTRON RES-5010 temperature controller:

1. Switch off the line voltage and the 24 VDC supply, and verify that the circuit is de-energized.
2. The supply voltage indicated on the nameplate of the RESISTRON temperature controller must be identical to the line voltage that is present in the system or machine. The line frequency is automatically detected by the RESISTRON temperature controller in the range from 47 Hz to 63 Hz.
3. Mount the RESISTRON temperature controller on a standard top hat rail (DIN TS35 rail according to DIN EN 50022) in the electrical cabinet. If several controllers are mounted on one rail, the minimum clearance specified in section 8 "Technical data" on page 43 must be allowed between them.
4. Wire the system in accordance with the instructions in section 4.3 "Power supply" on page 8, section 4.6 "Wiring diagram (standard)" on page 10, and the ROPEX Application Report. The information provided in section 4.2 "Installation steps" on page 7 must also be observed.
Wires used for control or measuring connections must always be laid inside the building.
5. An overcurrent protective device with a maximum rating of 10 A must be fitted when the device is installed, e.g.:
 - Miniature circuit breaker to EN 60898 (B, C, D, K, or Z characteristic)

- Miniature circuit breaker to UL 489 (*) (B, C, D, K, or Z characteristic)
- Fuse gG to IEC 60269
- Class CC or Class J fuse to UL 248 (*)

The overcurrent protective devices marked (*) should be used in installations conforming to UL standards.

If one such device is not adequate for the heatsealing application, two separate overcurrent protective devices should be provided – one for the controller and one for the application (↪ ROPEX Application Report).

The overcurrent protective device must be located directly adjacent to the controller.

The minimum possible specification for this device is indicated in the ROPEX Application Report based on the calculated currents. If a larger overcurrent protective device is fitted, you must match the current carrying capacity of the other components accordingly (e.g. cables, impulse transformer etc.).

6. A disconnecting device must be provided when the system is installed; it must be marked as belonging to the system and fitted in a readily accessible position.
If a miniature circuit breaker is used, it can also perform the function of this device.
7. Connect the RESISTRON temperature controller to the PROFINET controller using a suitable (standard compliant) cable.

 **Check that all system connections – including the terminals for the impulse transformer windings – are securely attached.**

8. Make sure the wiring conforms to all relevant national and international installation regulations.

4.2 Installation steps

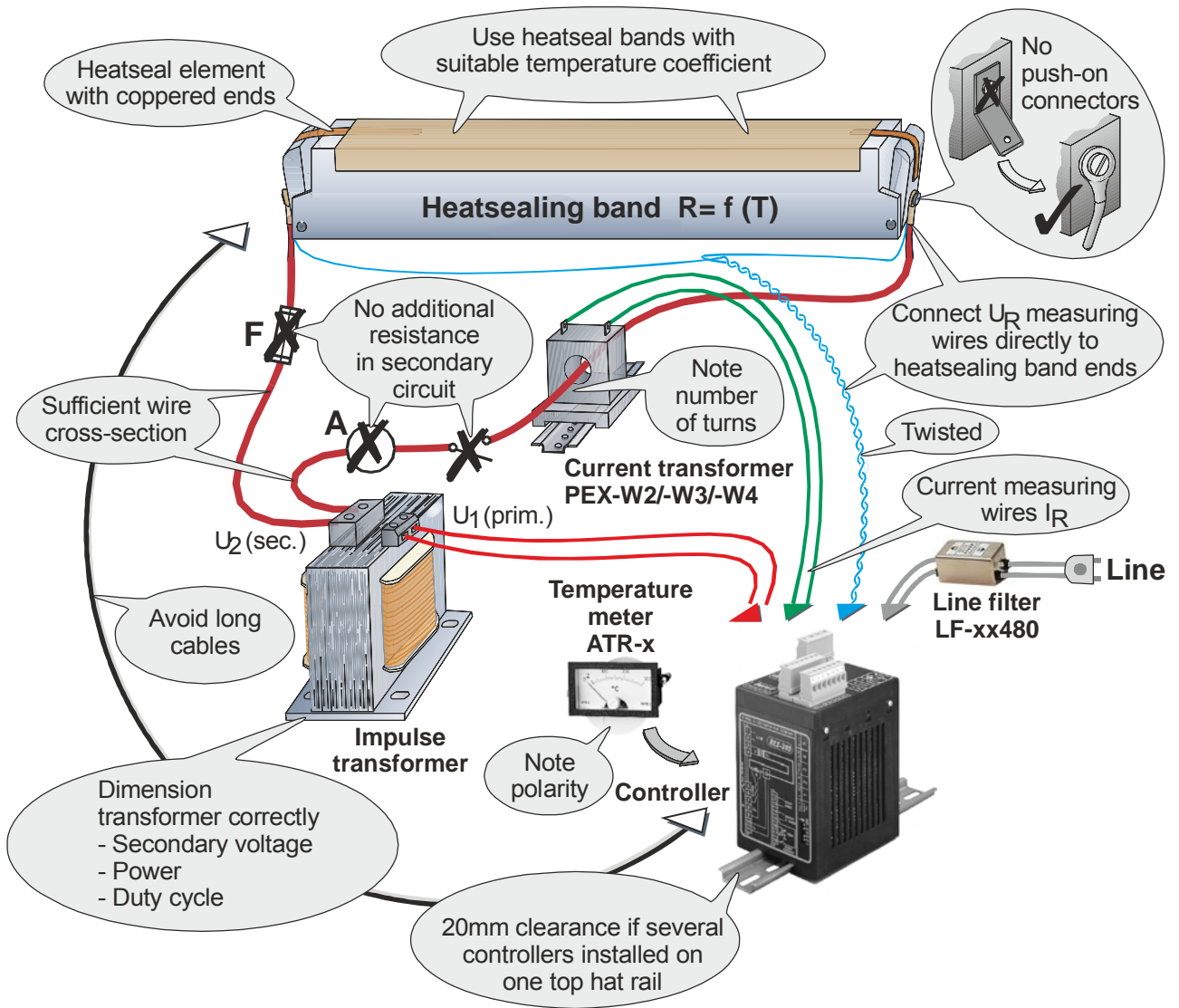

4.3 Power supply

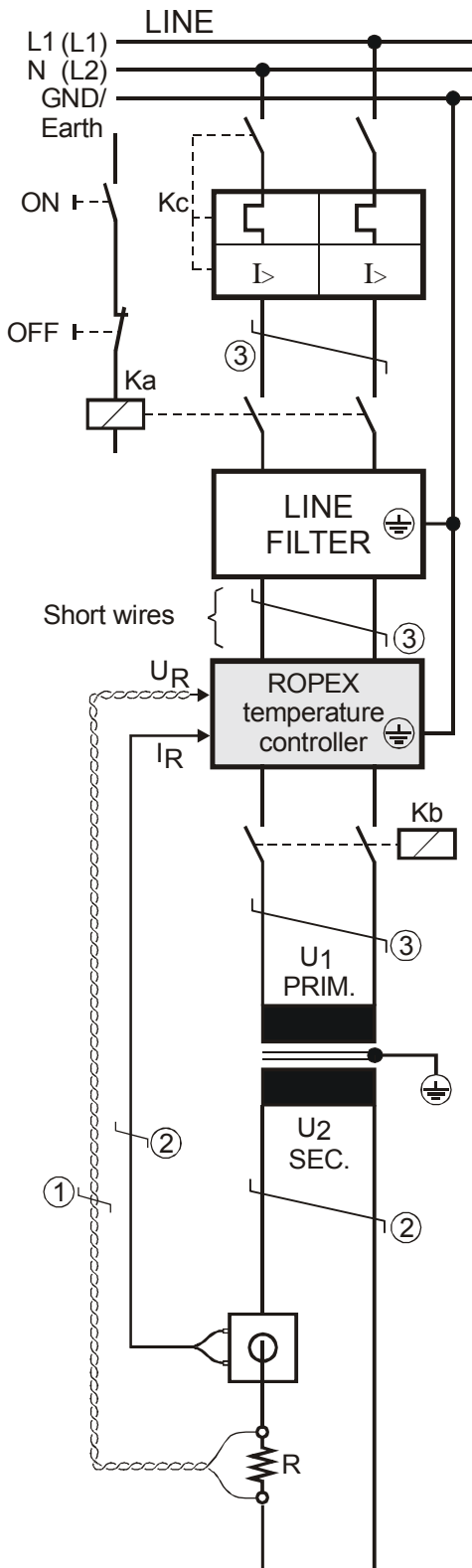

Line

115 VAC, 230 VAC, 400 VAC
50/60 Hz

Over-current protection

Double-pole circuit-breaker or fuses,
(☞ ROPEX Application Report)

⚠ Short-circuit protection only.

⚠ RESISTRON temperature controller not protected.

Relay Ka

For "HEAT ON - OFF" function (all-pole) or
"EMERGENCY STOP".

Line filter

The filter type and size must be determined according to
the load, the transformer and the machine wiring
(☞ ROPEX Application Report).

⚠ Do not run the filter supply wires (line side) parallel
to the filter output wires (load side).

RESISTRON temperature controller

Relay Kb

Load break (all-pole), e.g. in combination with the alarm
output of the temp. controller (ROPEX recommendation).

⚠ When using a series resistor RV-....-1 the relay Kb
shall be installed.

Impulse Transformer

Designed according to VDE 0570/EN 61558 (isolating
transformer with reinforced insulation). Connect core to
ground.

⚠ Use transformers with a one section bobbin. The
power, duty cycle and voltage values must be deter-
mined individually according to the application (☞ ROPEX
Application Report and "Accessories" leaflet for impulse
transformers).

Wiring

The wire cross-sections depend on the application
(☞ ROPEX Application Report).

Guide values:

Primary circuit: min. 1.5 mm², max. 2.5 mm²

Secondary circuit: min. 4.0 mm², max. 25 mm²

① Wires must always be twisted (min. 20 turns/meter).

② These wires must be twisted (min. 20 turns/meter)

if several control loops are laid together ("crosstalk").

③ Twisting (min. 20 turns/meter) is recommended to
improve EMC.

4.4 Line filter

To comply with EMC directives – corresponding to EN 50081-1 and EN 50082-2 – RESISTRON control loops must be operated with line filters.

These filters damp the reaction of the phase-angle control on the line and protect the controller against line disturbances.

! The use of a suitable line filter is part of the standards conformity and a prerequisite of the CE mark.

ROPEX line filters are specially optimized for use in RESISTRON control loops. Providing that they are installed and wired correctly, they guarantee compliance with the EMC limit values.

You can find the exact specification of the line filter in the ROPEX Application Report calculated for your particular heatsealing application.

For more technical information: ↪ "Line filter" documentation.

It is permissible to supply several RESISTRON control loops with a single line filter, providing the total current does not exceed the maximum current of the filter.

The wiring instructions contained in section 4.3 "Power supply" on page 8 must be observed.

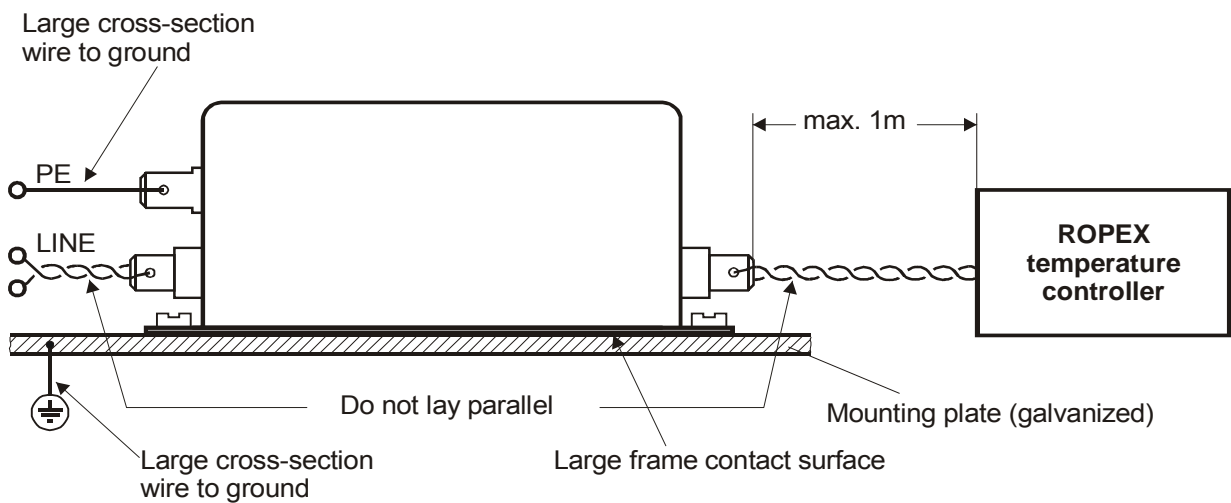

4.5 Current transformer PEX-W3/-W4

The PEX-W3/-W4 current transformer supplied with the RESISTRON temperature controller is an integral part

of the control system. The current transformer may only be operated if it is connected to the temperature controller correctly (↪ section 4.3 "Power supply" on page 8).

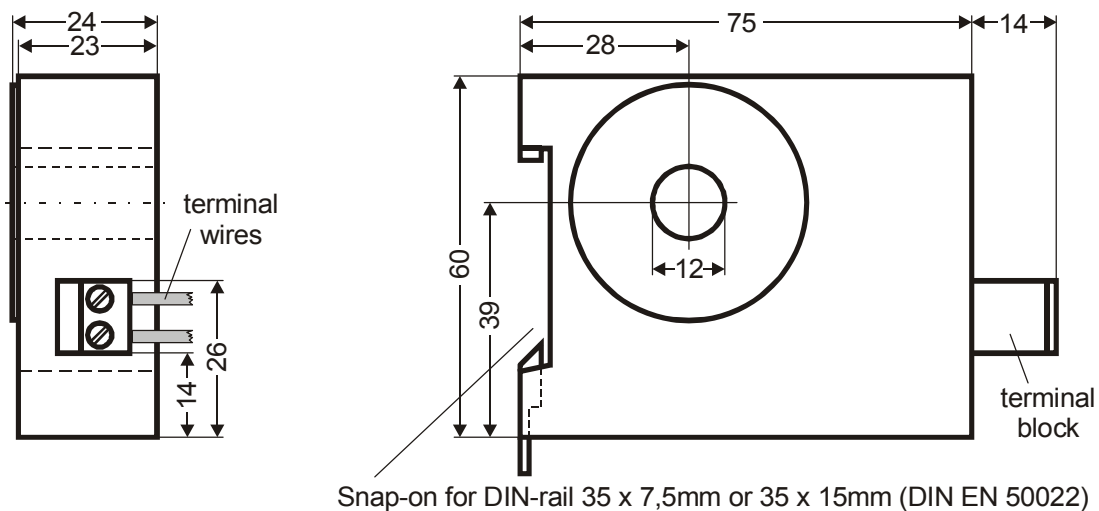

4.6 Wiring diagram (standard)

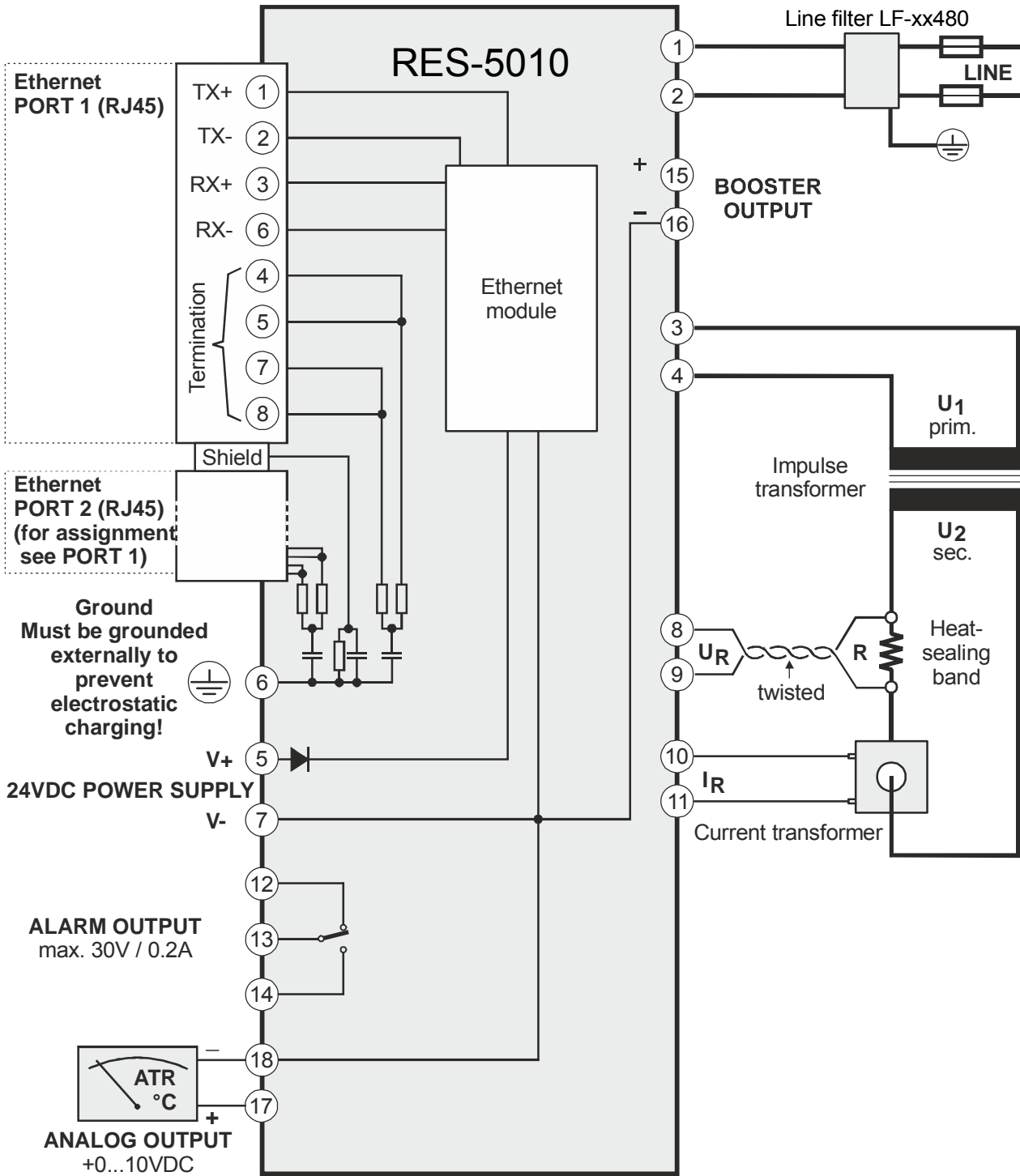

4.7 Wiring diagram with booster connection

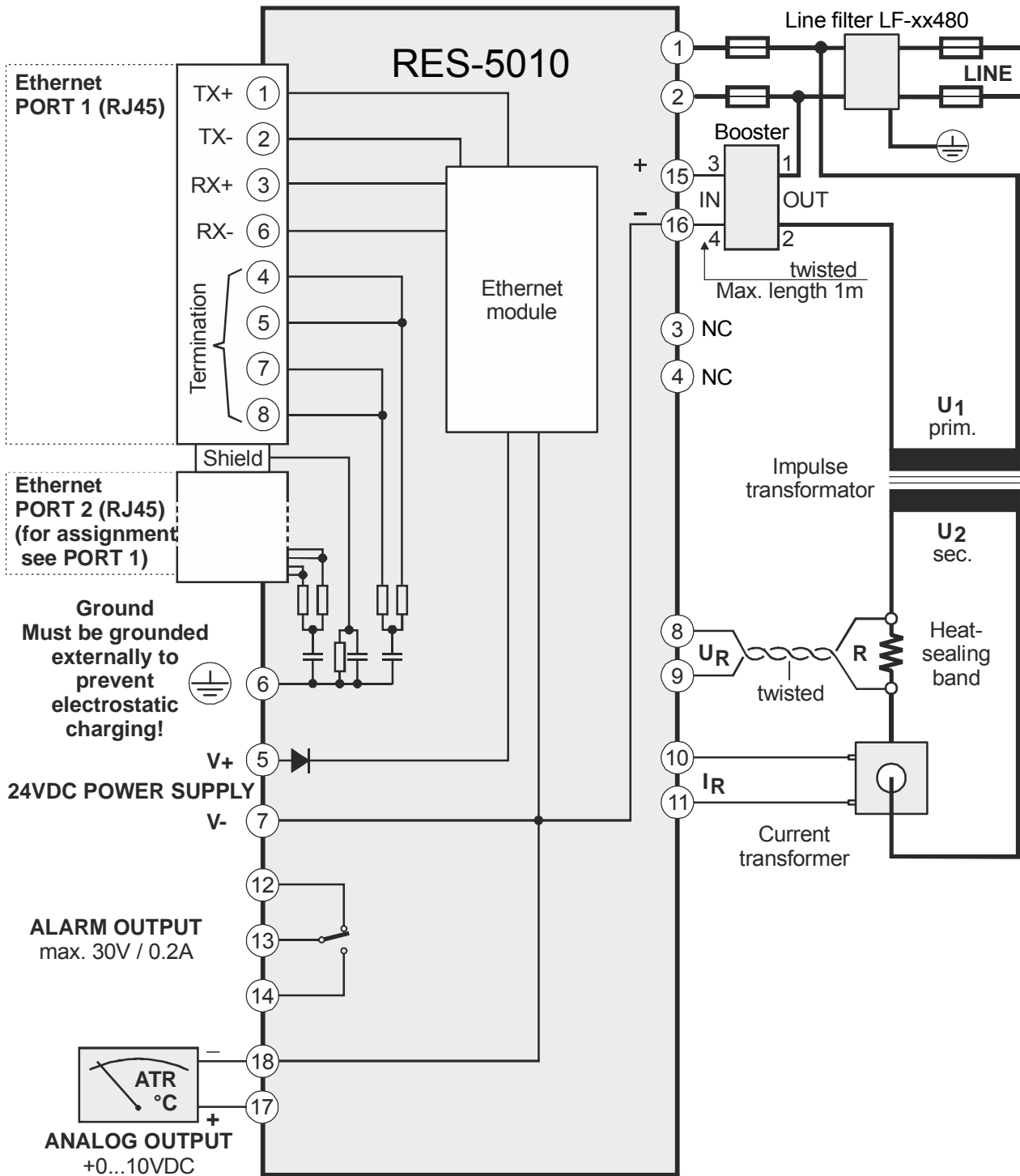

5 Startup and operation

5.1 View of the device

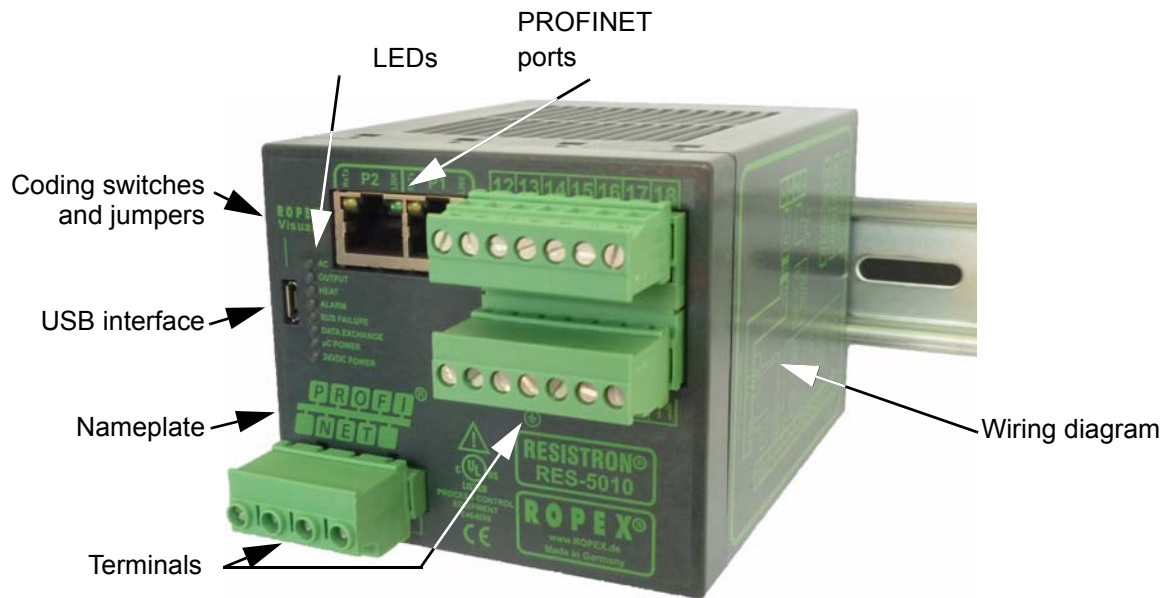

5.2 Device configuration

 **The controller must be switched off in order to configure the coding and slide switches.**

5.2.1 Configuration of the secondary voltage and current ranges

The secondary voltage and current ranges are automatically configured during the automatic calibration

function (AUTOCAL). The voltage is configured in the range from 0.4 VAC to 120 VAC and the current in the range from 30 A to 500 A. If the voltage and / or current are outside of the permissible range, a detailed error message appears on the controller (↪ section 6.19 "Error messages" on page 36).

If the secondary current I_2 is less than 30 A, the secondary high-current wire must be laid twice (or several times) through the PEX-W2, PEX-W3, or PEX-W4 current transformer (↪ ROPEX Application Report).



5.2.2 Configuration of the rotary coding switch for the temperature range and alloy

Switch position	Temp. range	Temp. coefficient	Band alloy
0	300°C	1100ppm/K	e.g. Alloy-20
1	300°C	780ppm/K	e.g. Alloy L
4	500°C	1100ppm/K	e.g. Alloy-20
5	500°C	780ppm/K	e.g. Alloy L
8	300°C	3500ppm/K	e.g. NOREX
9	PC-CONFIGURATION		

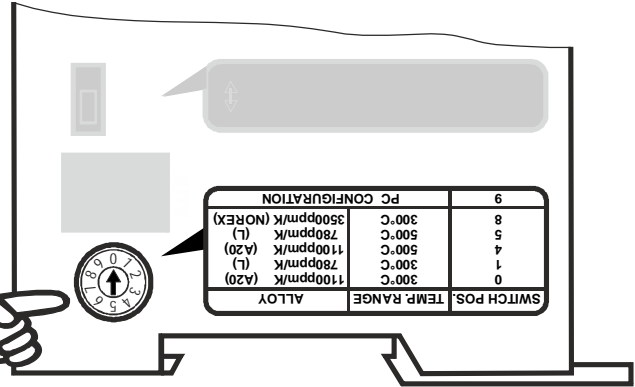
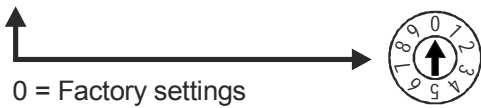

! The setting of the rotary coding switch for the temperature range and alloy can be overwritten with the parameter data (↪ section 6.7 "Parameter data" on page 24).

If the switch is set to "9", more temperature ranges and alloys can be selected in the ROPEX visualization software (↪ section 6.12 "USB interface for visualization software (ROPEXvisual®)" on page 34).

new setting does not take effect until the next time the controller is switched on. The preset device name "RES-5010" is configured as follows, depending on the settings of the rotary coding switches:

Rotary coding switch	Device name
00	Last name assigned is static
01...FE	RES-5010-01...RES-5010-FE
FF	Last device name assigned and I&M data erased

5.2.3 Configuration of the rotary coding switches for device names

These coding switches can be used to set the names of the RES-5010 devices in the PROFINET network. A

Station name selectable.

00 = Factory settings

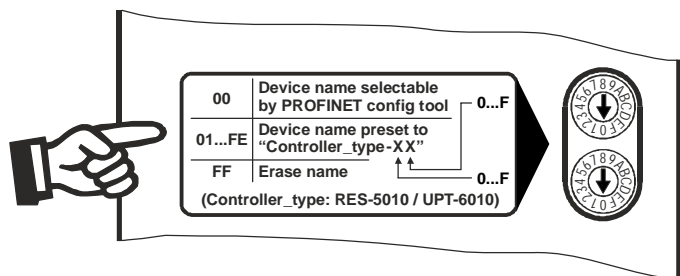

By assigning device names using rotary coding switches, you can replace a device in an existing machine without a programming tool. Simply configure the replacement device with the same switch settings. If the RES-5010 was named using a suitable PROFINET tool (e.g. Siemens STEP7), the preset device name can be erased by means of the rotary coding switches. To do this, make sure the controller is de-energized, then set the switches to 0xFF and switch the controller on again. It is sufficient to supply the controller with 24 VDC. No connection is required to the

PROFINET network. After the device name has been successfully erased, the red DATA EXCHANGE LED blinks at approx. 4 Hz. The power supply to the controller must then be momentarily interrupted in order for the new switch settings to take effect.

! In addition to the device name, restoring the factory settings by setting the rotary coding switch to "0xFF" also erases all I&M data in the memory.

! In order to assign the device name via the PROFINET interface (e.g. using a programming tool), the rotary coding switch must be set to "0x00".

Note: By using a configuring tool (e.g. Siemens STEP7) to specify the PROFINET topology, you can also assign

a name automatically if the controller does not already have a device name when it is switched on. In this case, the PLC automatically assigns it the name stored in the project.

5.2.4 Configuration of the alarm relay

Alarm relay contact opened by alarm/PC-CONFIGURATION.

Alarm relay contact closed by alarm. (factory setting)

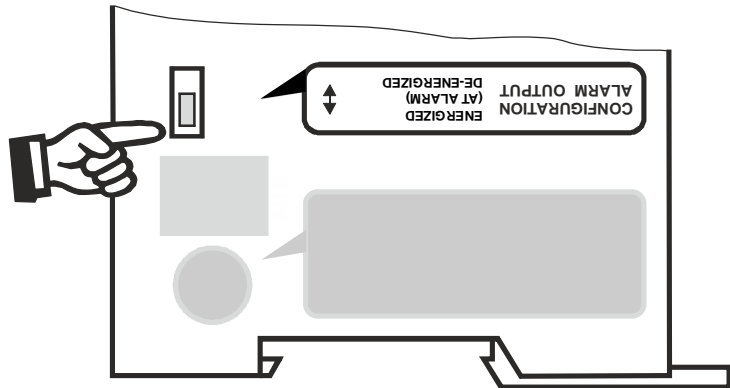
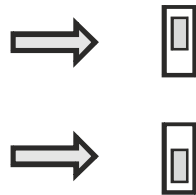

If the switch is set to "Alarm relay de-energized at alarm / PC CONFIGURATION", you can select more alarm output configurations in the ROPEX visualization

software (↘ section 6.12 "USB interface for visualization software (ROPEXvisual®)" on page 34).

5.3 Replacing and burning in the heatsealing band

5.3.1 Burning in the heatsealing band

The heatsealing band is a key component in the control loop because it is not only a heating element but also a sensor. The geometry of the heatsealing band is too complex to be discussed at length here. We shall therefore only refer to a few of the most important physical and electrical properties.

The measuring principle used for this system requires a heatsealing band alloy with a suitable temperature coefficient TCR. Too low a TCR leads to oscillation or uncontrolled heating.

If a heatsealing band with a higher TCR is used, the controller must be calibrated for it.

The first time the heatsealing band is heated to approximately 200...250°C, the standard alloy undergoes a once-only resistance change (burn-in effect). The cold resistance of the heatsealing band is reduced by approximately 2...3%. However, this at first glance slight resistance change results in a zero point error of 20...30°C. The zero point must therefore be corrected after a few heating cycles, i.e. the "AUTOCAL" function must be run again.

The burn-in effect described here does not occur if the heatsealing band has already been thermally pre-treated by the manufacturer.

! An overheated or burned-out heatsealing band must no longer be used because the temperature coefficient has been irreversibly altered.

One very important design feature is the copper or silver-plating of the heatsealing band ends. Cold ends allow the temperature to be controlled precisely and extend the life of the Teflon coating and the heatsealing band.

5.3.2 Replacing the heatsealing band

The supply voltage (all poles) must be disconnected from the RESISTRON® temperature controller in order to replace the heatsealing band.

! The heatsealing band must be replaced in accordance with the instructions provided by the manufacturer.

Each time the heatsealing band is replaced, you must calibrate the zero point with the "AUTOCAL" function while the band (and the environment, i.e. silicone,

PTFE cover, sealing bar etc.) is still cold in order to compensate production-related resistance tolerances. The burn-in procedure described above should be performed for all new heatsealing bands.

5.4 Startup procedure

Please also refer to section 1 "General information" on page 3 and section 2 "Application" on page 4.

 **Mounting, installation and startup may only be performed by authorized persons who have received suitable instruction and are familiar with the associated risks and warranty provisions.**

5.4.1 Initial startup

Condition: The device must be correctly installed and connected (↪ section 4 "Mounting and installation" on page 6).

Proceed as follows to start up the controller for the first time:

1. Switch off the line voltage and the 24 VDC supply, and verify that the circuit is de-energized.
2. The supply voltage indicated on the nameplate of the controller must be identical to the line voltage that is present in the system or machine. The line frequency is automatically detected by the temperature controller in the range from 47 to 63 Hz.
3. Link the device master file (GSDML) into the PROFINET controller (↪ section 6.3), then select the required parameters, assign a name to the device, and start the communication.
4. Make sure the "ST" bit is not set.
5. Switch on the line voltage and the 24 VDC supply (the order is arbitrary).
6. When the voltage is switched on, the yellow "AUTOCAL" LED lights up for approximately 0.3 seconds to indicate that the controller is being powered up correctly. The red "BUS FAILURE" LED lights up as long as no PROFINET communication is active. It does not go out again until it detects an active communication.

 **If the red "ALARM" LED lights up for 0.3...1.5 s when the voltage is switched on in addition to the yellow "AUTOCAL" LED, the configuration of this controller has been changed in the visualization software (↪ section 6.12 "USB interface for visualization software (ROPEXvisual®)" on page 34). In order to avoid malfunctions, please**

check the controller configuration before continuing the startup procedure.

7. The green "DATA EXCHANGE" LED lights up to indicate an active PROFINET communication.
8. One of the following states then appears:

"ALARM" LED	"OUTPUT" LED	ACTION
OFF	Short impulses every 1.2 s	Go to step 9
BLINKS fast (4 Hz)	OFF	Go to step 9
LIT continuously	OFF	<u>Error code 901</u> (error group: 7): No line voltage / sync signal (↪ section 6.2) <u>Otherwise:</u> Error diagnosis (↪ section 6.19)

9. Activate the "AUTOCAL" function while the heatsealing band is still cold by setting the "AC" bit (AUTOCAL) in the PROFINET protocol (↪ section 6.4 "Communication protocol" on page 20). The yellow "AUTOCAL" LED lights up for the duration of the calibration process (approx. 10...15 s). The "AA" bit (AUTOCAL active) is additionally set and a voltage of approximately 0 VDC appears at the actual value output (terminals 17+18). If an ATR-x is connected, it indicates 0...3°C.
After the zero point has been calibrated, the "AUTOCAL" LED goes out and a voltage of 0.66 VDC (300°C range) or 0.4 VDC (500°C range) appears at the actual value output. If an ATR-x is connected, it must be set to "Z".
If the zero point was not calibrated successfully, the "AL" bit (alarm active) is set and the red "ALARM" LED blinks slowly (1 Hz). In this case the controller configuration is incorrect (↪ section 5.2 "Device configuration" on page 12, ROPEX Application Report). Repeat the calibration after correcting the controller configuration.
10. After the zero point has been successfully calibrated, specify a defined temperature by means of the PROFINET protocol (set point) and set the "ST" bit. The "RA" bit (control active) is then activated

and the "HEAT" LED lights up. The heating and control process can be observed at the actual value output.

The controller is functioning correctly if the temperature (which corresponds to the signal change at the analog output or the actual value in the PROFINET protocol) is a regular curve, in other words it must not jump abruptly, fluctuate, or temporarily deviate in the wrong direction. This kind of behavior would indicate that the U_R measurement cable was laid incorrectly.

If an error code is displayed, proceed as described in section 6.19 "Error messages" on page 36.

11. Burn in the heatsealing band (↪ section 5.3 "Replacing and burning in the heatsealing band" on

page 14) and run the "AUTOCAL" function again.

5.4.2 Restart after replacing the heatsealing band

To replace the heatsealing band, proceed as described in section 5.3 "Replacing and burning in the heatsealing band" on page 14.

 **Always use a heatsealing band with the correct alloy, dimensions, and copper plating in order to avoid malfunctions and overheating.**

Continue with section 5.4, steps 4 to 11.

6 Device functions

See also section 4.6 "Wiring diagram (standard)" on page 10.

6.1 LEDs and controls

RX/TX (yellow LED)	Lit or blinking if Ethernet frames are transmitted.
LINK (green LED)	Lit if connection exists to Ethernet.
AUTOCAL (yellow LED)	Lit while AUTOCAL process is executing.
OUTPUT (Green LED)	Indicates pulses in measurement mode. In control mode, luminous intensity is proportional to heating current.
HEAT (yellow LED)	Lit during heating phase.
ALARM (Red LED)	Lit or blinking to indicate fault.
BUS FAILURE (red/green LED)	Lit or blinking if no connection exists to PROFINET.
DATA EXCH (red/green LED)	Lit (green) while data exchange with PROFINET controller.
µC POWER (green LED)	Lit if internal power supply for PROFINET interface is OK.
24V POWER (Green LED)	Lit if external 24VDC power supply is present.

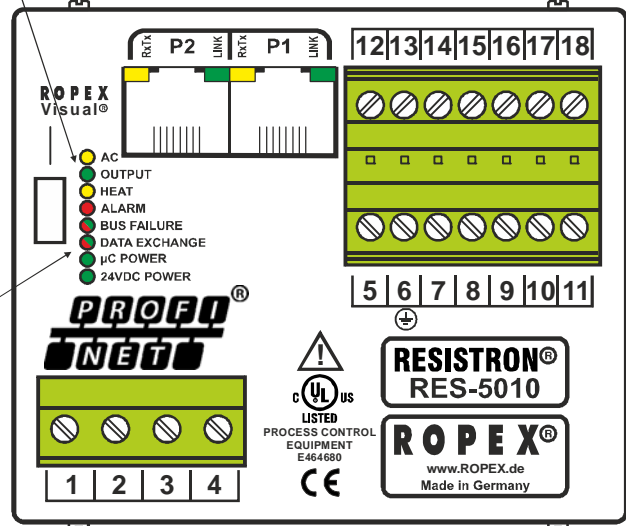

In addition to the functions shown above, the LEDs also indicate various controller operating states. These states are described in detail in the table below:

LED	Blinks slowly (1 Hz)	Blinks fast (4 Hz)	Lit continuously
AUTOCAL (yellow)	"RS" bit set (reset)	AUTOCAL requested but function blocked (e.g. START active)	AUTOCAL executing
	LED blinks at a different frequency: Supply voltages incorrect (too low)		
HEAT (yellow)	—	START requested but function blocked (e.g. AUTOCAL active, set temperature < 40 °C)	START executing
OUTPUT (green)	In control mode, luminous intensity is proportional to heating current.		
ALARM (red)	Configuration error, no AUTOCAL possible	Controller calibrated incorrectly, run AUTOCAL	Error, ↪ section 6.19
DATA EXCHANGE (red / green)	—	Rotary coding switches for device name set to 0xFF (factory setting restored)	Green: Communication with PROFINET controller is active Red: Internal error in PROFINET module
BUS FAILURE (red / green)	Blinks red for 3 s at 2 Hz: No data exchange Blinks (green or yellow) at 2 Hz: DCP signal service activated via bus		Red: No communication or slow / no physical connection
LINK PORT 1, 2 (green)	—	—	Connection exists to Ethernet
RX / TX PORT 1, 2 (yellow)	Device is transmitting / receiving Ethernet frames		

6.2 PROFINET communication

The following sections only describe controller-specific functions. For general information on the PROFINET interface and the system configuration, please refer to the description of your PLC.

The PROFINET interface of the RES-5010 supports "Conformance Class C" with IO/RT and IRT according to IEC 61784-2.

The controller can communicate via the PROFINET interface provided the 24 VDC supply voltage (terminals 19+20) is present.

If no line voltage is present however (e.g. if it is switched off in order to open a door), error code 901 or 201 (error group 7, no line voltage / sync signal) appears on the controller and the alarm relay is switched. This happens due to the absence of line voltage. The error message can be reset by switching on the line voltage again and setting the "RS" bit (↪ section 6.5.3 "Reset (RS)" on page 22).

You can easily process the error code that appears if the line voltage is switched off – or suppress switching of the alarm relay – in the PLC program.

6.3 Device master file (GSDML)

The configuring tools for the PROFINET controller interpret the content of the device master files (GSDML) and use this information to create a parameter set for the PROFINET controller which controls user data traffic. The *GSDML-V2.32-ROPEX-0150-RES-5010-20151014.XML* file of the RES-5010 contains all essential controller information for the configuration, e.g. the I/O data description, parameter descriptions, error messages etc. The device master files and the associated image files (.BMP) for visualization in the configuring tool can be requested by e-mail (support@ropex.de) or downloaded from our website (www.ropex.de). If the controller already has an IP address, the device master file can also be downloaded from the integrated web server.

After linking the required device master file into the configuring tool, you must assign a unique name to the controller (device initialization). The controller is shipped without a name. You must also select the desired parameter values.

6.4 Communication protocol

The communication protocol consists of 2x16 bit input words and 3x16 bit output words (from the point of view of the controller). This protocol separates the set point and the actual value of the RES-5010 from the status

information and the control functions, to simplify decoding by the PROFINET controller.

Bits 0...7 form the low byte and bits 8...15 the high byte ("INTEL format").

The 2 x 16-bit **input data** contains the set point in word ① and the control functions in word ②:

①	Spare							Set point / AC temperature									
Name:	0	0	0	0	0	0	0										
Bit no.:	15	14	13	12	11	10	9	8	7	6	5	4	3	2	1	0	

②	Spare					Channel			Spare			Control function				
Name:	0	0	0	0	0	CH2	CH1	CH0	0	0	0	MA	MP	RS	ST	AC
Bit no.:	15	14	13	12	11	10	9	8	7	6	5	4	3	2	1	0

The 3 x 16-bit **output data** contains the actual value in word ①, the status information in word ②, and the error code in word ③:

①	Actual value (signed)															
Name:																
Bit no.:	15	14	13	12	11	10	9	8	7	6	5	4	3	2	1	0

②	Spare				Channel			Status information								
Name:	0	0	0	0	CH2	CH1	CH0	SA	IA	WA	AA	AG	AL	TE	TO	RA
Bit no.:	15	14	13	12	11	10	9	8	7	6	5	4	3	2	1	0

③	Error code															
Name:	0	0	0	0	0	0	A9	A8	A7	A6	A5	A4	A3	A2	A1	A0
Bit no.:	15	14	13	12	11	10	9	8	7	6	5	4	3	2	1	0

If the optional "Temperatures" submodule has been configured, the controller returns another 16-bit output word with the start temperature:

①	Start temperature (signed)															
Name:																
Bit no.:	15	14	13	12	11	10	9	8	7	6	5	4	3	2	1	0

6.5 Input data

The term "input data" refers to the data that is transferred from the PROFINET controller to the RES-5010. It contains the set point as well as the control functions

such as START or AUTOCAL for the RES-5010. These functions are explained in the following.

If the PROFINET controller marks its output data with the IOPS "bad" or does not transmit any data at all, all

bits are set to 0 (inactive). An active heatsealing process is interrupted.

6.5.1 Automatic zero calibration "AUTOCAL" (AC)

Owing to the automatic zero calibration (AUTOCAL) function, there is no need to adjust the zero point manually on the controller. This function adjusts the controller to the current and voltage signals present in the system and calibrates it to the value which is predefined in the parameter data (↪ section 6.7.4 "Variable calibration temperature" on page 28). If no parameter data is transferred by the PROFINET controller, the default value is 20°C.

Some PROFINET controllers do not allow the parameter data to be changed during operation. In this case, the calibration temperature cannot be adapted to the actual ambient conditions in the machines.

The calibration temperature can thus be specified by means of the "Set point / AC temperature" input data whenever the zero point is calibrated, provided this is permitted in the parameter data (↪ section 6.7.4 "Variable calibration temperature" on page 28). You can specify it in the 0...+40°C range. The specified calibration temperature must be entered in the "Set point / AC temperature" input data when the "AUTOCAL" function is activated ("AC" bit = 1). This specified value must not be changed until the "AUTOCAL" function has finished. If the specified temperature is too high (greater than 40°C) or if the specified value fluctuates, an error message appears (error codes 115 and 116; ↪ section 6.19 "Error messages" on page 36).

The AUTOCAL request ("AC" bit = 1) is executed by the controller provided the "AUTOCAL" function is not blocked.

The automatic calibration takes around 10...15 seconds. The heatsealing band is not heated during this process. The yellow LED on the front panel lights up while the "AUTOCAL" function is executing and the controller shows "AUTOCAL active" ("AA" bit = 1) in the output data. The actual value output (terminals 17+18) changes to 0...3°C (corresponds to approx. 0 VDC).

If the temperature of the heatsealing band fluctuates, the "AUTOCAL" function is executed a maximum of three times. If the function still cannot be executed successfully, an error message appears (↪ section 6.19 "Error messages" on page 36).

The "AUTOCAL" function should only be activated while the heatsealing band (and the environment, i.e. silicone, PTFE cover, sealing bar etc.) is still cold (base temperature).

Reasons for blocked "AUTOCAL" function:

1. An AUTOCAL request cannot be accepted until 10 seconds after the controller is switched on. During this time the controller shows "AUTOCAL blocked" ("AG" bit = 1) in the output data.
2. The "AUTOCAL" function is not activated if the heatsealing band cools down at a rate of more than 0.1 K/s. If the "AC" bit is set, the function is automatically executed when the cooling rate falls below the specified value.
3. If the "START" bit is set ("ST" bit = 1), the "AUTOCAL" function is not executed ("HEAT" LED lit).
4. If the "RESET" bit is set ("RS" bit = 1), the "AUTOCAL" function is not executed.
5. The "AUTOCAL" function cannot be activated if error codes 101...103, 201...203, 801 or 9xx appear as soon as the controller is switched on (↪ section 6.19 "Error messages" on page 36). It also cannot be activated if error codes 201...203, 801, or 9xx appear and the controller has operated correctly at least once since being switched on.

If the "AUTOCAL" function is blocked ("AG" bit = 1), an AUTOCAL request ("AC" bit = 1) causes the "AUTOCAL" LED to blink fast (4 Hz).

6.5.2 Start (ST)

When the "START" bit is set ("ST" bit = 1), the controller's internal set / actual comparison is enabled and the heatsealing band is heated to the SET temperature. It remains at this temperature either until the "ST" bit is reset or until the actual heating time exceeds the preset heating time limit (↪ section 6.7.5 "Heating time limit" on page 28).

The "HEAT" LED on the front panel of the RES-5010 lights up continuously for the duration of the heating time.

A start request is not processed as long as the "AUTOCAL" function is active, a fault is present on the controller, the set point is less than 20°C higher than the calibration temperature, or the "RS" bit is set. In this case, the "HEAT" LED blinks.

The heatup process is terminated if the "ST" bit is reset or if a PROFINET error occurs.

The "ST" bit is only accepted if the "AUTOCAL" function is deactivated and there are no faults.

The alarm relay is switched if the "ST" bit is set while a warning with error code 8...12 (104...106, 111...114, 211, 302, or 303) is indicated (↪ section 6.19 "Error

messages" on page 36). The heating element is not heated.

6.5.3 Reset (RS)

This bit resets the controller if the controller shows a fault.

No AUTOCAL or START requests are accepted as long as the "RS" bit is set. Until it is reset again, only error codes 5 and 7 (201...203, 901, 913) are evaluated and output by the error diagnosis function. The power unit is not activated in this state and no measuring impulses are generated. As a result of this, the actual value is no longer updated. The reset request is not accepted until the "RS" bit is reset. PROFINET communications are not interrupted by a controller reset.

The controller actual value output changes to 0...3°C (i.e. approximately 0 VDC) and the "SA" status bit is set in order to set the "RS" bit.

The "AUTOCAL" function is not canceled if the "RS" bit is set while it is executing.

The controller performs an internal initialization lasting approximately 500 ms after the "RS" bit is reset. The next heatsealing process cannot be started until it has finished.

If a Kb contactor is used to deactivate the control loop (↪ section 4.3 "Power supply" on page 8), it must be reliably energized again 200 ms at the latest after the "RS" bit is reset (note the contactor switching and delay times). If it is energized too late, an error message appears on the controller.

6.5.4 Measurement pause (MP)

No more measuring impulses are generated by the controller as soon as the "MP" bit is set. Until it is reset again, only error codes 5 and 7 (201...203, 901, 913) are evaluated and output by the error diagnosis function. In addition, the actual value is no longer updated. The last valid value before the bit was set is output. As soon as the bit is reset, new measuring impulses are generated, all error messages are evaluated, and the actual value is updated again.

This bit is only active in measurement mode. "ST", "RS", and "AC" take priority.

The bit is suitable for all applications in which the electrical connections of the heatsealing band must be disconnected during normal operation without triggering a fault (e.g. sliding rail contacts).

Unlike the "RS" bit (RESET), the "MP" bit does not reset any faults when it is set. The controller is active again as soon as the bit is reset, in other words there is no initialization phase.

When the controller is switched on, it does not evaluate the "MP" bit until the system test (including the functional test of the heating circuit) has been successfully completed. This can take several hundred milliseconds.

6.5.5 Master AUTOCAL (MA)

Setting this control bit starts a calibration as described in section 6.5.1 "Automatic zero calibration "AUTOCAL" (AC)" on page 21. However, if the "AUTOCAL" function is successful, the heatsealing band resistance which is determined by the controller is also used as a reference value, e.g. after replacing the heatsealing band.

This reference value serves to calculate the deviation from the calibration value for all subsequent calibrations (initiated with the "AC" bit). This deviation helps you assess aging of the heatsealing band.

The deviation from the calibration value is queried by means of acyclic read accesses to the optionally configurable "Calibration deviation" module.

6.5.6 Channel selection (CH0...CH2)

The temperature controller has separate memories for up to eight calibration data records. A calibration data record contains the values determined by the temperature controller during the "AUTOCAL" function. By storing the calibration data records, you can alternate between different sealing tools without having to run the "AUTOCAL" function every time the tool is changed. You only need to execute AUTOCAL if you connect a new heatsealing band.

Since different calibration values, AUTOCAL temperatures, and temperature coefficients are stored in the controller for this purpose, the required calibration data record 0...7 can be selected with the three bits CH0...CH2. You can switch to another channel at any time.

This function is useful, for instance, in applications where frequent changes of format are necessary. The tools can then be changed as required in order to handle the different formats. A channel containing the relevant calibration data record is assigned to each tool. Once all tools have been calibrated with a unique channel assignment, they can be changed at any time simply by selecting the appropriate channel.

If the application does not require any format changes, the channel can remain set to 0. In this case, the temperature controller behaves in exactly the same way as older models where different calibration data records are not supported.

It is possible to switch to another channel during the "AUTOCAL" function; however, the controller continues working with the original channel until the "AUTOCAL" function has finished. The channel currently being used by the controller is shown in the status information.

6.5.7 Set point

A set point of up to 300°C or 500°C is allowed, depending on the selected temperature range (↪ section 6.7.1 "Temperature range and alloy" on page 27). If you attempt to enter a higher set point, it is limited internally to 300°C or 500°C.

6.6 Output data

The term "output data" refers to the data that is transferred from the RES-5010 to the PROFINET controller. It contains the current actual value as well as all important information on the current status of the controller. If a fault is signaled, it can be diagnosed accurately with the help of the error code.

6.6.1 AUTOCAL active (AA)

The "AA" bit indicates that the "AUTOCAL" or "AUTO-COMP" function is executing.

6.6.2 AUTOCAL blocked (AG)

If the "AG" bit is set, the "AUTOCAL" function is temporarily blocked. This is the case if "START" is active or the heatsealing band is still in the cooling phase.

6.6.3 Alarm active (AL)

If the "AL" bit is set, an alarm has been triggered but not yet reset. The error code provides information on the exact cause (↪ section 6.19 "Error messages" on page 36).

6.6.4 Warning active (WA)

This bit can be set in addition to the "AL" bit. If the "WA" bit is set, a warning is output to indicate the current fault. In this case, the alarm relay is not active.

6.6.5 Temperature achieved (TE)

The "TE" bit is set if the actual temperature exceeds 95% of the set temperature. This status bit is reset again as soon as you exit control mode ("ST" bit = 0) or a fault is signaled ("AL" bit = 1).

6.6.6 Temperature OK (TO)

The RES-5010 checks whether the actual temperature is within a settable tolerance band ("OK" window) either side of the set temperature. The high ($\Delta\vartheta_{high}$) and low ($\Delta\vartheta_{low}$) limits of the tolerance band can be changed independently of one another in the parameter data (↪ section 6.7 "Parameter data" on page 24). The following settings are possible:

1. **"Off"**
The "TO" bit is always reset.
2. **"Active when Tact = Tset" (factory setting)**
The "TO" bit is set if the actual value is inside the specified temperature tolerance band. If the actual temperature is outside of the tolerance band, the "TO" bit is reset (see graph below).

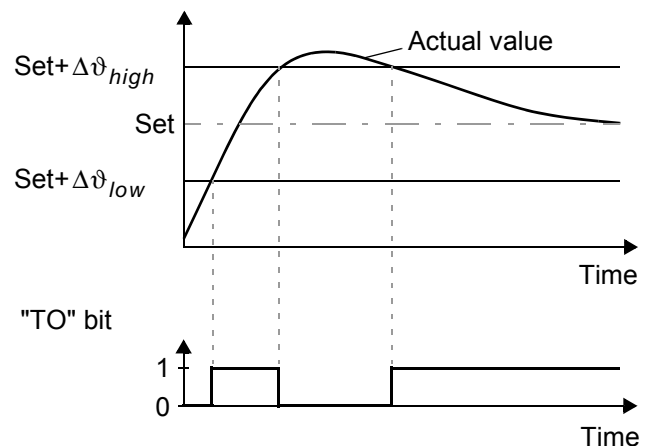

Unlike the "Temperature achieved" status bit ("TE" bit), the actual temperature is evaluated independently of the control mode.

3. **"Active when Tact = Tset" with latch function**
A heatsealing cycle starts when the "ST" bit is set. The "TO" bit is set when the actual temperature reaches the temperature tolerance band for the first time during a heatsealing cycle. If the actual temperature leaves the tolerance band again while the "ST" bit is still set, the "TO" bit is reset (Fig. a.). If the actual temperature does not leave the tolerance band while the "ST" bit is still set, the "TO" bit is not reset until the start of the next heatsealing cycle (latch function, Fig. b.). The switching state of the "TO" bit can thus be queried after the "ST" bit has been reset and before the start of the next heatsealing cycle.

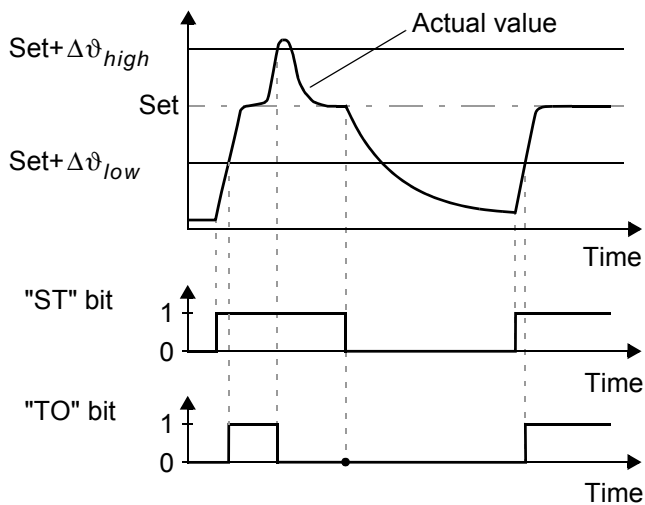
a.) Temperature *not* OK

b.) Temperature OK

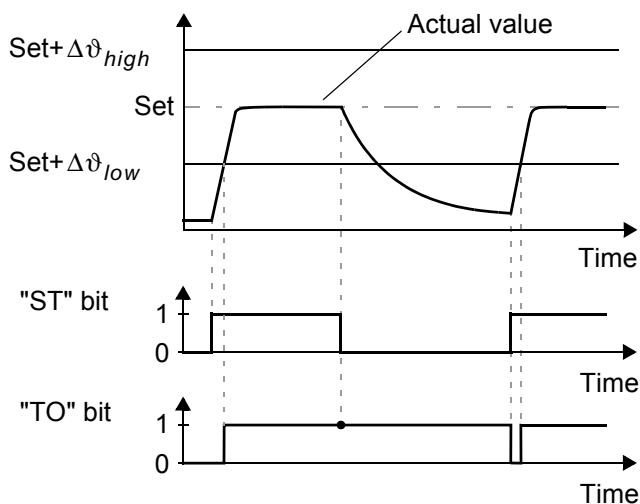

! The limits of the tolerance band are adjustable up to a maximum of ± 99 K.

6.6.7 Control active (RA)

The RES-5010 has successfully accepted the "START" request and entered control mode if the "RA" bit = 1.

6.6.8 Info active (IA)

This bit is reserved for future use and is not currently supported (it is always set to 0).

6.6.9 Standby active (SA)

This bit is active if the "RS" bit is set. It shows the PLC when the controller has accepted the "RS" or "MP" bit, so that these bits can be reset again (handshake).

6.6.10 Actual value

All 16 bits of the first word must be interpreted as a signed number (two's complement notation). The resolution is 1°C . During the calibration procedure or if a fault occurs, the actual value is 0.

6.6.11 Start temperature

If the optional "Temperatures" submodule has been configured, the controller returns another 16-bit output word with the last start temperature: This is the temperature which was measured just before the start command was executed ("ST" bit = 1). This value allows you to evaluate the cooling process. It is only valid during the heating phase ("ST" bit = 1). Outside of this phase the value -99°C appears, so that it is possible to distinguish between valid and invalid values. The normal value range is between -20°C and 500°C .

6.6.12 Error codes

If a fault is signaled ("AL" bit = 1), you can determine the exact cause with the help of the error code. The error code is contained in the third word at bit positions 0...9 (see section 6.19 "Error messages" on page 36). In addition to the error codes, the PROFINET diagnosis function also sends error messages to the PROFINET controller. The error messages corresponding to each error code are already stored in the device master file (GSDML), so that they automatically appear in plain text on the PROFINET controller when a device diagnosis for the RES-5010 is requested there. The error messages are stored in the GSDML file in English and German. You can select the language in the configuration tool.

6.7 Parameter data

The parameter data contains values for selecting the heatsealing band alloy, the temperature range, the high and low tolerance limits for temperature monitoring, the calibration temperature, and the optional heating time limit. It is transferred from the PROFINET controller to the RES-5010 each time the system is started up. The parameters can also be queried by the PROFINET controller or transmitted by it to the RES-5010 controller at any time using asynchronous read / write services. They are not stored in the RES-5010. The parameter

data can be addressed at slot 1, subplot 1, starting at index 4; it has the following structure:

Index	Function	Default value ¹	Value range
4	Temperature range / alloy	10	0, 1, 4, 5, 8, 10, 11 (↳ 6.7.1)
5	Low temperature OK threshold	10 K	3...99 K
6	High temperature OK threshold	10 K	3...99 K
7	Calibration temperature	20°C	-1, 0...40°C
8/9	Heating time limit (100 ms steps)	0	0...999 (0...99.9 s)
10	External module / channel errors	On	Off (0), on (1)
11	Measuring impulse duration	17	17...30 (1.7...3.0 ms)
12	Data format	Little Endian (Intel)	Little Endian (Intel) (0), Big Endian (Motorola) (1)
13/14	Temperature coefficient	1100 ppm/K	400...4000 ppm/K
15	Temperature range	300°C	200°C (0), 300°C (1), 400°C (2), 500°C (3)
16/17	Maximum temperature	300°C	200...500°C
18	Temperature diagnosis	Off	Off (0), on (1)
19	Temperature diagnosis delay (100 ms steps)	0 s	0...99 (0...9.9 s)
20/21	Heatup timeout (100 ms steps)	0 s	0...999 (0...99.9 s)
22	AUTOCOMP	Off	Off (0), on (1), auto (2)
23	Temperature OK bit	Active when Tact=Tset	Off (0), active when Tact=Tset (1), active when Tact=Tset with latch (2)
24	Hold mode	Off	Off (0), on (1), 2 s (2)
25	Calibration temperature, channel 1	20°C	-1, 0...40°C
26/27	Temperature coefficient, channel 1	1100 ppm/K	400...4000 ppm/K
28	Calibration temperature, channel 2	20°C	-1, 0...40°C
29/30	Temperature coefficient, channel 2	1100 ppm/K	400...4000 ppm/K
31	Calibration temperature, channel 3	20°C	-1, 0...40°C
32/33	Temperature coefficient, channel 3	1100 ppm/K	400...4000 ppm/K
34	Calibration temperature, channel 4	20°C	-1, 0...40°C
35/36	Temperature coefficient, channel 4	1100 ppm/K	400...4000 ppm/K

Index	Function	Default value ¹	Value range
37	Calibration temperature, channel 5	20°C	-1, 0...40°C
38/39	Temperature coefficient, channel 5	1100 ppm/K	400...4000 ppm/K
40	Calibration temperature, channel 6	20°C	-1, 0...40°C
41/42	Temperature coefficient, channel 6	1100 ppm/K	400...4000 ppm/K
43	Calibration temperature, channel 7	20°C	-1, 0...40°C
44/45	Temperature coefficient, channel 7	1100 ppm/K	400...4000 ppm/K

1. The default value is stored in the device master file (GSDML) and transferred from the PROFINET controller to the RES-5010 when the system is started up.

The date, time, operating hours counter, and counters for the individual calibration channels can be read out at slot 1, subslot 2. Apart from the operating hours counter (index 4...7) and the non-clearable total cycle counter (index 8...11), these counters can also be reset by means of a write access.

A plausibility check which takes account of leap years is performed after writing the date or time. If the trans-

ferred values do not contain any valid date or time information, the RES-5010 responds with an access error: 0xb7 "Invalid Range". To prevent inconsistencies, the individual date or time values should be changed together with a single write access, in other words index 0...3 and 4...7.

Index	Function	Default value	Value range
0	Date: Day		1...31
1	Date: Month		1...12
2/3	Date: Year		2000...2099
4	Time: Milliseconds (not used) ¹	0	0...99
5	Time: Seconds		0...59
6	Time: Minutes		0...59
7	Time: Hours		0...23
8...11	Operating hours (in 0.1 h)	0.0 h	0...99999999.9 h
12...15	Non-clearable total cycle counter	0	0...999999999
16...19	Clearable total cycle counter	0	0...999999999
20...23	Cycle counter, channel 0	0	0...999999999
24...27	Cycle counter, channel 1	0	0...999999999
28...31	Cycle counter, channel 2	0	0...999999999
32...35	Cycle counter, channel 3	0	0...999999999
36...39	Cycle counter, channel 4	0	0...999999999
40...43	Cycle counter, channel 5	0	0...999999999
44...47	Cycle counter, channel 6	0	0...999999999
48...51	Cycle counter, channel 7	0	0...999999999

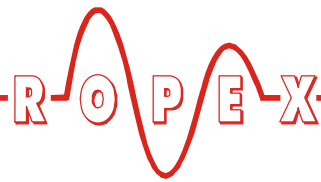

1. Milliseconds are not supported by the internal real-time clock. Read accesses always return 0. A value in the range 0...99 must be transferred during write accesses or the RES-5010 will respond with an access error: 0xb7 "Invalid Range".

The start temperature (↪ section 6.6.11 "Start temperature" on page 24) and the internal device temperature are available at slot 1, subplot 3. They are read-only values which cannot be written,

Index	Function	Default value	Value range
0/1	Start temperature	-99°C	-99°C...500°C
2/3	Device temperature		-60...190°C

The channel-specific deviations from the calibration data are available at slot 1, subplot 4 (↪ section 6.5.5 "Master AUTOCAL (MA)" on page 22). They are read-only values which cannot be changed,

Index	Function	Default value	Value range
0/1	Calibration deviation, channel 0	0	-100%...100%
2/3	Calibration deviation, channel 1	0	-100%...100%
4/5	Calibration deviation, channel 2	0	-100%...100%
6/7	Calibration deviation, channel 3	0	-100%...100%
8/9	Calibration deviation, channel 4	0	-100%...100%
10/11	Calibration deviation, channel 5	0	-100%...100%
12/13	Calibration deviation, channel 6	0	-100%...100%
14/15	Calibration deviation, channel 7	0	-100%...100%

6.7.1 Temperature range and alloy

This parameter determines both the temperature range and the heatsealing band alloy. You can overwrite the setting of the rotary coding switch (↪ section 5.2.2 "Configuration of the rotary coding switch for the temperature range and alloy" on page 13) by changing the default value (10).

Value	Temperature range	Alloy
0	300°C	TCR = 1100 ppm/K, z.B. Alloy 20
1	300°C	TCR = 780 ppm/K, e.g. Alloy L
4	500°C	TCR = 1100 ppm/K, z.B. Alloy 20
5	500°C	TCR = 780 ppm/K, e.g. Alloy L

Value	Temperature range	Alloy
8	300°C	TCR = 3500 ppm/K, e.g. NOREX
9	PC setting (visualization software)	PC setting (visualization software)
10	Rotary coding switch setting	Rotary coding switch setting
11	Variable: Parameter index 15 is used.	Variable: Parameter index 13/14 is used.

By setting this parameter to 11, you apply the value stored at index 15 to the temperature range and the value stored at index 13/14 to the alloy. You must always execute the "AUTOCAL" function after changing the "Temperature range / alloy", "Temperature range", or "Temperature coefficient" parameter.

6.7.2 Low temperature OK threshold

Low threshold value for the "OK" window.

Refer to section 6.6.6 "Temperature OK (TO)" on page 23 and section 6.7.10 "Temperature diagnosis" on page 29.

6.7.3 High temperature OK threshold

High threshold value for the "OK" window.

Refer to section 6.6.6 "Temperature OK (TO)" on page 23 and section 6.7.10 "Temperature diagnosis" on page 29.

6.7.4 Variable calibration temperature

The calibration temperature is set to 20°C by default. You can change it to another value between 0°C and 40°C in order to adapt it to the temperature of the cold heatsealing band.

Some PROFINET controllers do not allow the parameter data to be changed during operation. In this case, the calibration temperature cannot be adapted to the actual ambient conditions in the machines.

The calibration temperature can thus be enabled for setting by means of the input data by specifying the value "-1" in the parameter data. The calibration temperature can then be specified via the "Set point / AC temperature" input data (↪ section 6.5.1 "Automatic zero calibration "AUTOCAL" (AC)" on page 21).

You do not need to run the "AUTOCAL" function after changing the calibration temperature.

6.7.5 Heating time limit

The heating time limit provides additional protection against unwanted continuous heating. The controller automatically deactivates the heating impulse after the set heating time limit has elapsed if the start bit remains set for longer than the time specified with this limit. The start bit must be reset before the controller can be started up again.

The heating time limit is deactivated by default (0) but can be set to any value between 0 s and 99.9 s (0 and 999).

6.7.6 External module / channel errors

The device diagnosis uses the diagnostic channel of the PROFINET protocol to display any RES-5010 errors directly on the PROFINET controller. There is a text message stored in the device master file (GSDML) for each error which is automatically displayed in plain text on the PROFINET controller, provided the controller has this capability.

The display of external module / channel errors can be activated or deactivated by means of the parameter at index 8. The default setting for external module / channel errors is "on".

You can check the controller status by means of the user data regardless of this parameter.

6.7.7 Measuring impulse duration

The length of the measuring impulses generated by the controller can be set with this parameter. It may be necessary to set a measuring impulse longer than the default 1.7 ms for certain applications.

6.7.8 Data format

This parameter specifies the order of the bytes ("Little Endian (Intel)" or "Big Endian (Motorola)") in the cyclic data; this setting applies to both input and output data (↪ section 6.4 "Communication protocol" on page 20). We recommend selecting "Big Endian (Motorola)" for Siemens PLCs.

6.7.9 Automatic phase angle compensation (AUTOCOMP)

It may be necessary to compensate the phase angle displacement between the U_R and I_R measuring signals for specific heatsealing applications (↪ ROPEX Application Report). The "AUTOCOMP" function is provided for this purpose. The following settings are possible:

1. "Off" (factory setting)
The "AUTOCOMP" function is switched off.
2. "On"
The "AUTOCOMP" function is executed whenever the "AUTOCAL" function (↪ section 6.5.1 "Automatic zero calibration "AUTOCAL" (AC)" on page 21) is executed twice in quick succession. The interval between the end of the first "AUTOCAL" function and the start of the second "AUTOCAL" must be shorter than 2.0 s. The second "AUTOCAL" function only takes around 2.0 s and includes the "AUTOCOMP" function.
If the interval between the two "AUTOCAL" functions is longer than 2.0 s, "AUTOCAL" is executed normally again the second time.

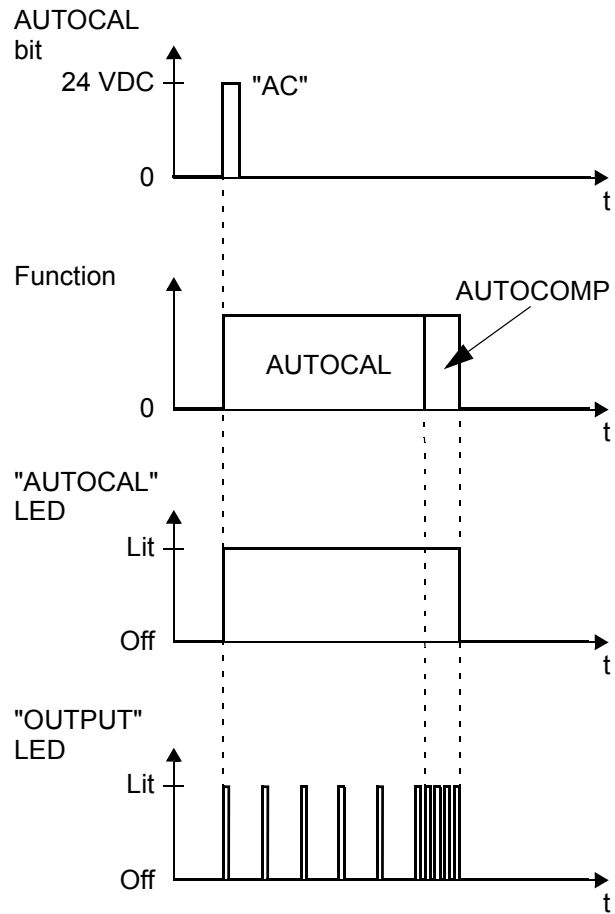
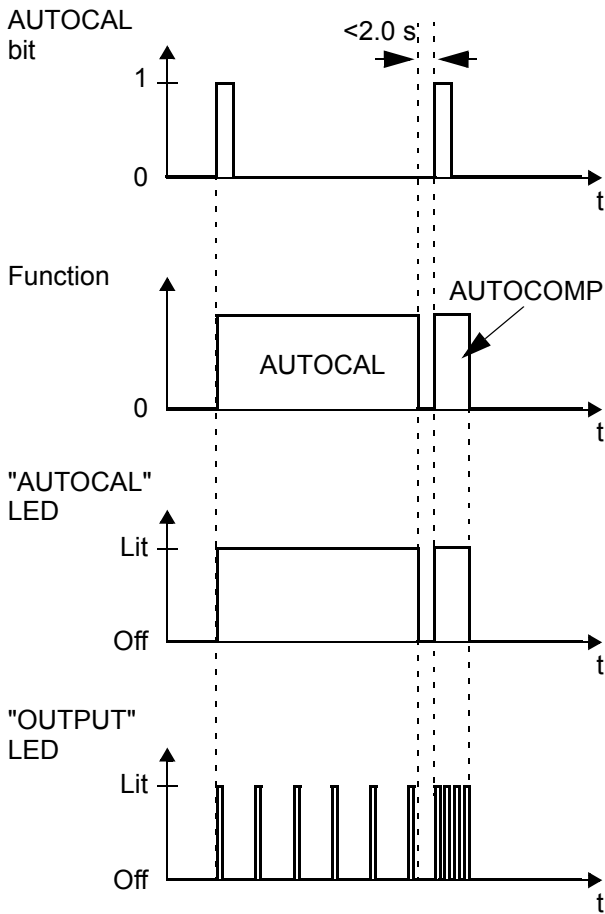

The "OUTPUT" LED blinks several times when the "AUTOCOMP" function is executed and the actual value output (terminals 17+14) changes to 0...3°C (corresponds to approx. 0 VDC).

The "OUTPUT" LED blinks several times when the "AUTOCOMP" function is executed and the actual value output (terminals 17+14) changes to 0...3°C (corresponds to approx. 0 VDC).

3. "AUTO"

This setting causes the "AUTOCOMP" function to be automatically activated after the "AUTOCAL" function has been successfully executed.

The "AUTOCOMP" function must be activated in the parameter data (↪ section 6.7 "Parameter data" on page 24) (default setting: AUTOCOMP off).

6.7.10 Temperature diagnosis

An additional temperature diagnosis can be activated in the parameter data (GSDML file). The RES-5010 checks whether the actual temperature is within a settable tolerance band ("OK" window) either side of the set temperature. The high ($\Delta\vartheta_{high}$) and low ($\Delta\vartheta_{low}$) tolerance limits are the same as for the "Temperature OK" function ("TO" bit ↪ section 6.6.6 "Temperature OK (TO)" on page 23). The limits are set to -10 K and +10 K by default.

If the ACTUAL temperature is inside the specified tolerance band when the "START" signal is activated, the temperature diagnosis is activated as well. If the ACTUAL temperature leaves the tolerance band, the corresponding error code (307, 308) appears and the

alarm relay is switched (↪ section 6.19 "Error messages" on page 36).

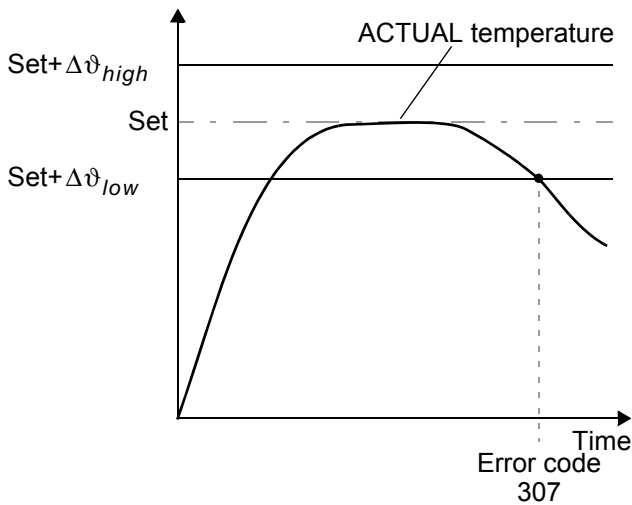

If the temperature diagnosis is not activated by the time the "START" signal is deactivated (i.e. if the ACTUAL temperature does not exceed the high or low tolerance band limit), the corresponding error code (309, 310) appears and the alarm relay is switched.

An additional delay time (0..9.9 s) can be set in the parameter data (GSDML file). The first time the low tolerance limit is exceeded, the temperature diagnosis is not activated until the configured delay time has elapsed. The temperature diagnosis function can thus be selectively deactivated, e.g. if the temperature drops temporarily owing to the closure of the sealing jaws.

The high and low tolerance limits cannot be set in the ROPEX visualization software. The same limits apply as with the "TO" bit. They can only be set in the parameter data (↪ section 6.7 "Parameter data" on page 24).

6.7.11 Heatup timeout

An additional heatup timeout can be activated in the parameter data (GSDML file).

This timeout starts when the "ST" bit is set. The RES-5010 then monitors the time required for the ACTUAL temperature to reach 95% of the SET temperature. If this time is longer than the configured time, the corresponding error code (304) appears and the alarm relay is switched (↪ section 6.19 "Error messages" on page 36).

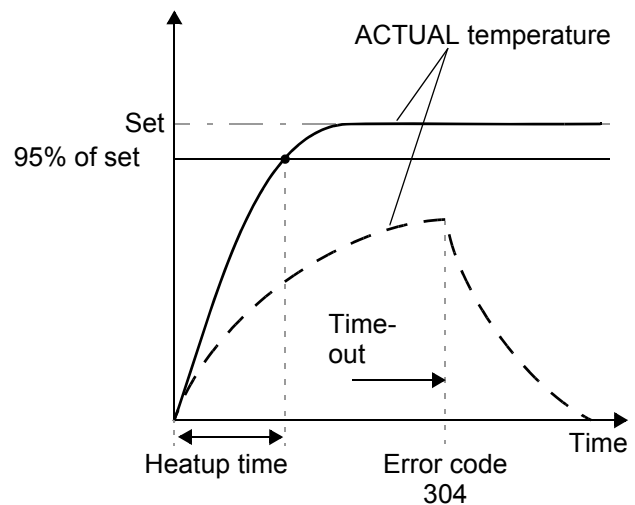

The "Heatup timeout" function must be enabled for use in the parameter data (↪ section 6.7 "Parameter data" on page 24) (default setting: heatup timeout off).

6.7.12 Hold mode

The ACTUAL temperature output via the PROFINET protocol can be configured in the parameter data (GSDML file) as follows:

1. **"Off" (factory setting)**
The ACTUAL temperature is always output in real time.
2. **"On"**
The ACTUAL temperature that was valid at the end of the last heatsealing phase is output. When the controller is switched on, the real ACTUAL temperature is indicated up until the end of the first heating phase.
3. **"2 s"**
This setting causes the current ACTUAL temperature to be output for an additional 2 seconds by means of the PROFINET protocol at the end of a heatsealing phase. The ACTUAL temperature is then output again in real time until the end of the next heatsealing phase.

Hold mode only applies to the ACTUAL temperature which is output via the PROFINET protocol and the digital temperature display in the ROPEX visualization software. It has no effect on the ACTUAL temperature that appears at the controller's analog output or is plotted in the graphics window of the ROPEX visualization software.

The various hold modes are shown below:

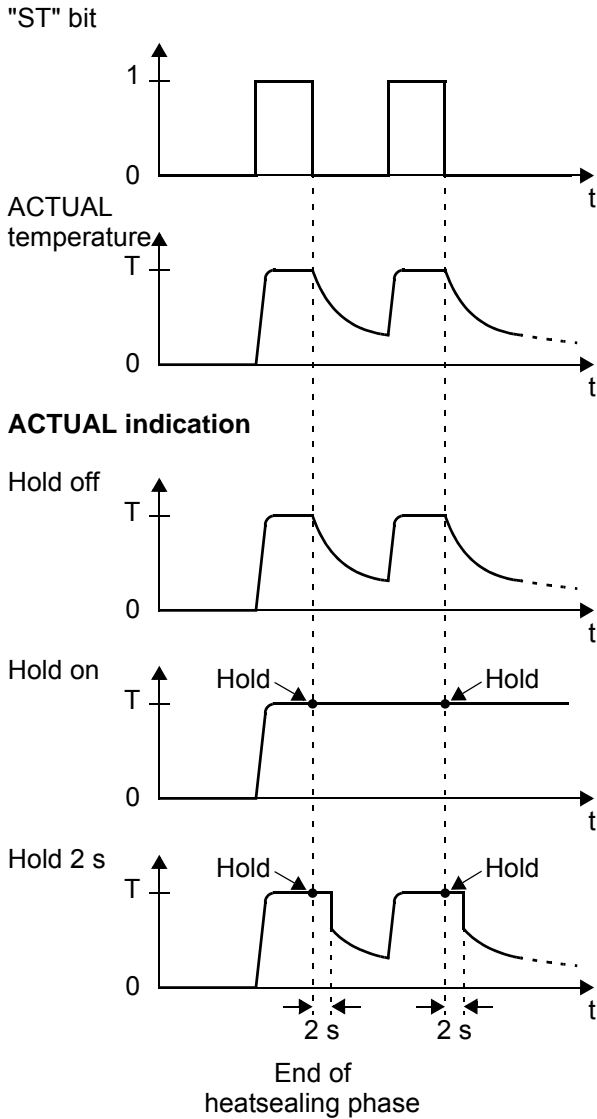

The "Hold mode" function must be activated in the parameter data (↪ section 6.7 "Parameter data" on page 24) (default setting: hold mode off).

6.8 Integrated web server

The integrated web server enables quick and easy access to status information and parameter values of the temperature controller via the existing Ethernet connection. The device protocol can additionally be read out and displayed. A graph showing the last 10 seconds of a heating impulse allows a rapid qualitative evaluation of the controlled system.

The latest version of the operating instructions can be downloaded from the ROPEX website by clicking on the picture of the device on any page. To make sure this latest version is always available in any selectable language, the instructions are not stored in the device; you must therefore have an Internet connection in order to access the operating instructions.

You can go direct to the official ROPEX website by clicking on the ROPEX logo in the top right-hand corner.

The web server uses JavaScript and has been successfully tested with Internet Explorer 9, 10, and 11 as well as with Microsoft Edge. It also works with the latest version of the Safari and Firefox browsers.

6.8.1 Home page

This page contains general product information under "Device Information", for instance the product name, serial number, firmware version, MAC address, and real-time Ethernet protocol. You can also download the correct device description file for your product here (↪ section 6.3 "Device master file (GSDML)" on page 19). No Internet connection is necessary to do this because the file is already stored in the device's internal memory.

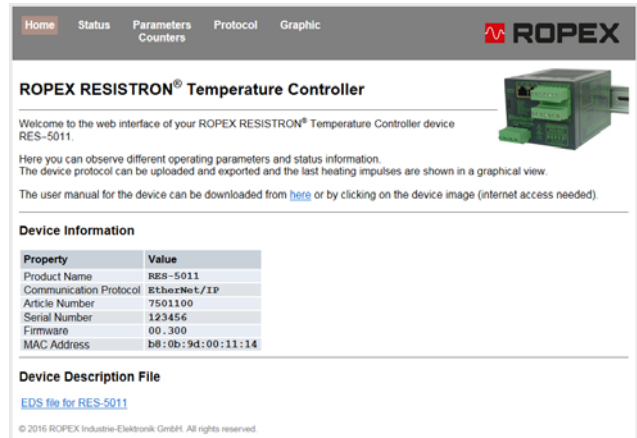

6.8.2 Status page

This page provides an overview of the current controller status.

"Online" indicates whether a connection has been set up to the PLC.

The inputs (↪ section 6.5 "Input data" on page 20) are shown in the left-hand column, the outputs (↪ section 6.6 "Output data" on page 23) in the middle column, and the current status of all device LEDs

(↩ section 6.1 "LEDs and controls" on page 17) in the right-hand column.

6.8.3 Parameters / Counters page

This page shows all parameter values received by the temperature controller from the PROFINET controller. If the parameters have been changed using acyclic services, these changes are also indicated here. For the meanings of the parameter data, refer to section 6.7 "Parameter data" on page 24. Under "Counters" you see a list of all cycle and operating hours counters, which are useful for statistical purposes.

6.8.4 Protocol page

You can download and display the device protocol for the temperature controller on this page. You see the

overall size of the protocol ("Total event entries") as well as the upload progress. All entries appear in the form of a table. A timestamp (generated by the built-in clock), the operating hours and cycle counters, and the channel selected at the time are shown for each entry. In addition to errors, the protocol also contains entries of general interest such as "Clock set" or the "AUTOCAL" function. An error code provides information on the cause of all events in the protocol. The error codes are described in detail in section 6.19 "Error messages" on page 36. Each error code is explained in a tooltip when you hover over it briefly.

The data can also be exported to a CSV file to enable further processing in another software program. By clicking on the appropriate button you can select a comma separated format or a semicolon separated format.

The download may take a few seconds, depending on the number of entries which are stored here. The newest events appear at the top of the list.

If any new events occur while this page is displayed, you do not see them until you refresh the list by clicking on the "Protocol" menu again.

6.8.5 Graphic page

The temperature controller has an internal memory which can store temperature curves over a period of up to 10 seconds. This memory is automatically filled when the "ST" bit is set. You can display or export the memory contents on the Graphic page.

By clicking on "Refresh", you cause the graphic data to be downloaded from the memory of the temperature controller and displayed again.

"Clear" clears all data from the memory (disconnecting the 24 VDC supply voltage has the same effect).

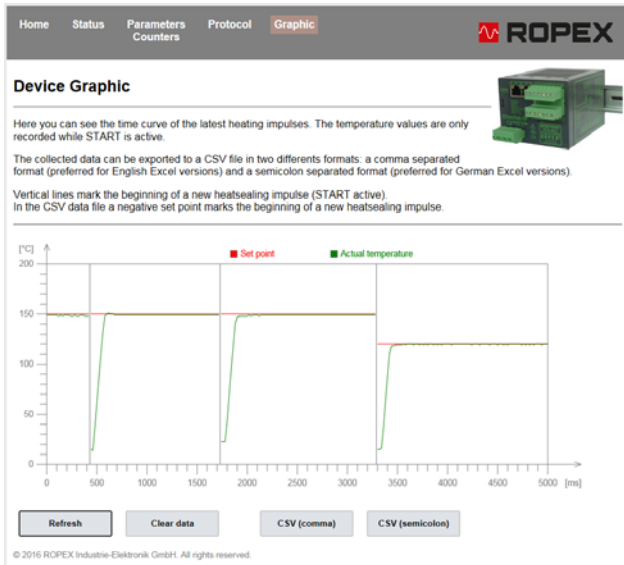

The vertical lines mark the beginning of a new heatsealing impulse ("ST" bit set). A negative set point indicates the start of a new impulse in the exported data. Cooling processes are not normally visible because they take place when the "ST" bit is reset.

6.9 Undervoltage detection

Trouble-free operation of the temperature controller is guaranteed within the line voltage and 24 VDC supply voltage tolerances specified in section 8 "Technical data" on page 43.

If the 24 VDC supply voltage drops below the permitted lower limit, the controller is switched to standby mode. No more heatsealing processes take place and no more measuring impulses are generated. Normal operation is resumed when the input voltage returns to the specified tolerance range again.

Standby mode is indicated by 0...3°C (i.e. approx. 0 V) at the analog output. In addition, the "SA" bit is set in the status word for the cyclic output data.

! Trouble-free operation of the controller is only guaranteed within the specified tolerance range of the input voltage. An external voltage monitor must be connected to prevent low line or 24 VDC supply voltage from resulting in defective heatseals.

The relationship between the change in the output

6.10 Temperature meter (actual value output)

The RES-5010 supplies an analog 0...10 VDC signal, which is proportional to the real ACTUAL temperature, at terminals 17+18.

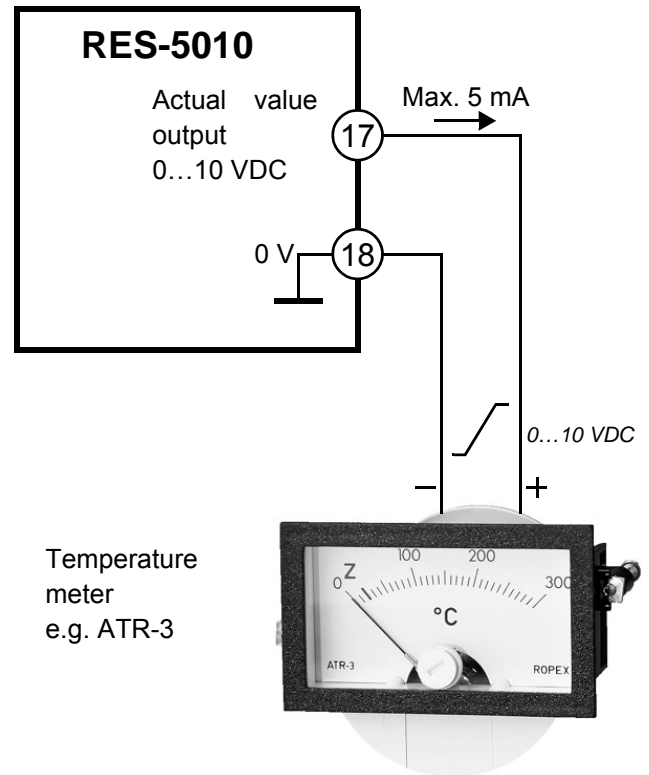

Temperature meter e.g. ATR-3

Voltage values:

0 VDC → 0°C

10 VDC → 300°C or 500°C

(depending on the device configuration)

voltage and the ACTUAL temperature is linear.

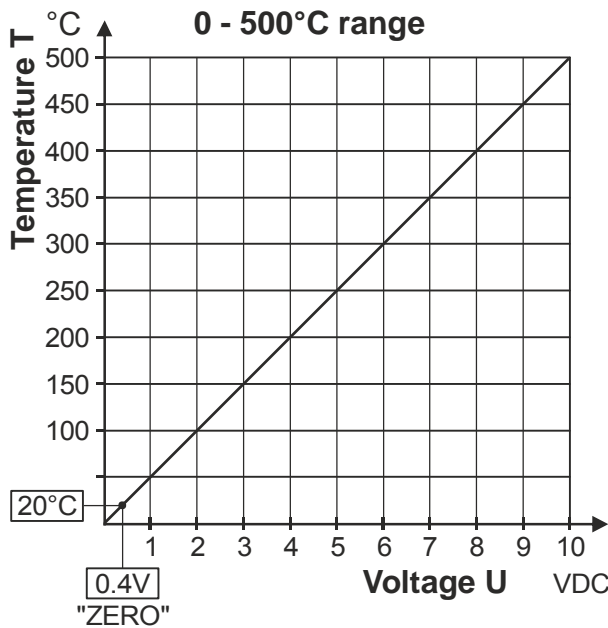
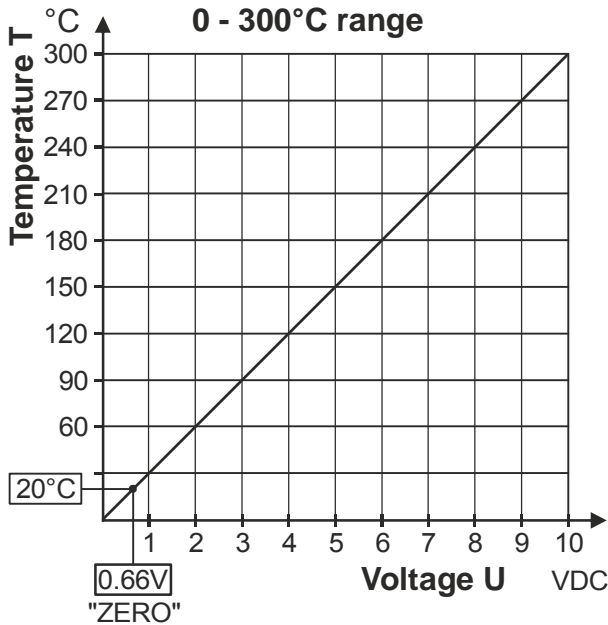

An indicating instrument can be connected to this output in order to visualize the temperature of the heatsealing band.

The ROPEX ATR-x temperature meter is optimally adapted to this application in every respect (size, scale, dynamic behavior), which is why this particular meter should always be used (↪ section 4 "Mounting and installation" on page 6).

The meter not only facilitates SET-ACTUAL comparisons but also enables other criteria such as the heating

rate, set point achieved within the specified time, cooling of the heatsealing band etc. to be evaluated. The temperature meter additionally permits disturbances in the control loop (loose connections, contacting or wiring problems) as well as any line disturbances to be observed extremely efficiently and interpreted accordingly. The same applies if several neighboring control loops interfere with one another. If a fault is signaled, this analog output is used to display a selective error message (↪ section 6.19 "Error messages" on page 36).

6.11 Booster connection

The RES-5010 controller has a connection for an external switching amplifier (booster) as standard. This connection (at terminals 15+16) is necessary for high primary currents (continuous current > 5 A, pulsed current > 25 A). The booster should be connected as described in section 4.7 "Wiring diagram with booster connection" on page 11.

⚠ The connecting cable to the booster must not be longer than 1 m; it must also be twisted in order to reduce EMC interference to a minimum.

6.12 USB interface for visualization software (ROPEXvisual®)

A USB interface (type: Micro USB) is provided for system diagnostics and process visualization. This USB interface enables a data connection to be set up to ROPEXvisual®, the ROPEX visualization software.

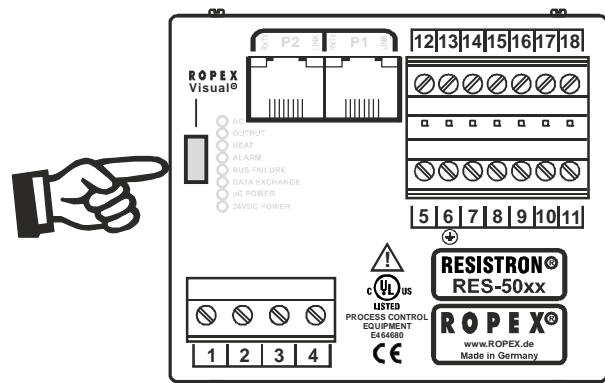

The ROPEX visualization software is described in a separate document.

6.13 AUX interface

Internal interface for diagnostics and maintenance. This interface is not currently available.

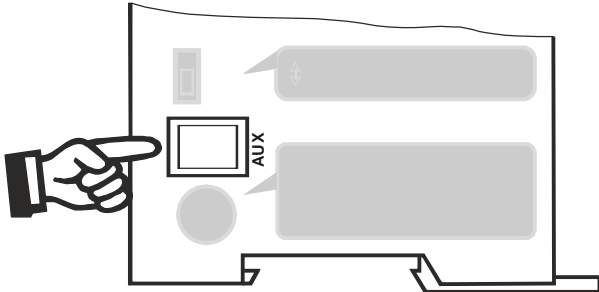

6.14 Total cycle counter

The number of heatsealing cycles executed since the controller was shipped is stored in the internal memory ("ST" bit = 1). This is a read-only counter which cannot be reset. It can be displayed in the ROPEX visualization software (↪ section 6.12 "USB interface for visualization software (ROPEXvisual®)" on page 34), via the integrated web server, or using the acyclic services of the PROFINET interface.

6.15 Operating hours counter

The number of operating hours since the controller was shipped is stored in the internal memory. This counter works with a resolution of six minutes. It is a read-only counter which cannot be reset. It can be displayed in the ROPEX visualization software (↪ section 6.12 "USB interface for visualization software (ROPEXvisual®)" on page 34), via the integrated web server, or using the acyclic services of the PROFINET interface.

6.16 Data memory for error messages and AUTOCAL

To simplify error diagnoses during operation, the RES-5010 controller has a data memory for error messages (↪ section 6.19 "Error messages" on page 36) and executed AUTOCAL functions (↪ section 6.5.1 "Automatic zero calibration "AUTOCAL" (AC)" on page 21).

The 400 most recent messages are stored. They can be read out and displayed in the ROPEX visualization

software (↪ section 6.12 "USB interface for visualization software (ROPEXvisual®)" on page 34) or via the integrated web server.

The RES-5010 also features a built-in clock (↪ section 6.17 "Built-in clock (date and time)" on page 35). All messages are saved in the data memory together with their date and time of occurrence (timestamp).

6.17 Built-in clock (date and time)

The RES-5010 has a built-in clock. All messages are saved in the data memory (↪ section 6.16 "Data memory for error messages and AUTOCAL" on page 35) together with their date and time of occurrence (timestamp). Error messages can thus be interpreted more accurately whenever a problem needs to be analyzed.

The built-in clock can be set and read out in the ROPEX visualization software (↪ section 6.12 "USB interface for visualization software (ROPEXvisual®)" on page 34) or using the acyclic services of the PROFINET interface. The date and time can be read out but not set via the integrated server.

A maintenance-free capacitor is used to operate the clock. There is no battery that has to be replaced every now and then.

The controller must remain switched on for at least three hours to make sure the clock's capacitor is fully charged. When the controller is switched off, the fully charged capacitor can keep the clock running for approximately 2...4 weeks. If the controller is switched off for longer, the date and time will have to be set again. You can do this in the ROPEX visualization software (↪ section 6.12 "USB interface for visualization software (ROPEXvisual®)" on page 34) or using the acyclic services of the PROFINET interface.

The capacitor is not charged when it leaves the factory. When the controller is started up, you must set the clock if you want error messages to be saved in the data memory (↪ section 6.16 "Data memory for error messages and AUTOCAL" on page 35) together with their date and time of occurrence.

The controller can also be operated without the clock. In this case, the dates and times that are saved in the data memory will be invalid (↪ section 6.16 "Data memory for error messages and AUTOCAL" on page 35). However, this has no effect on the temperature control functions.

6.18 System monitoring / alarm output

To increase operational safety and avoid faulty heatsealing, this controller incorporates special hardware and software features to facilitate selective error detection and diagnosis. Both the external wiring and the internal system are monitored.

These features significantly assist the operator in identifying the cause of abnormal situations.

A system fault is reported or differentiated by means of the following indications.

A.) Red "ALARM" LED on the controller with three states:

1. Blinking fast (4 Hz):

The "AUTOCAL" function should be executed (error codes 104...106, 211, 302, 303).

2. Blinking slowly (1 Hz):

The system configuration is incorrect and the zero calibration ("AUTOCAL" function) was unsuccessful (↪ section 5.2 "Device configuration" on page 12). This corresponds to error codes 111...114).

3. Lit continuously:

A fault is preventing the system from starting (error codes 101...103, 107, 108, 201...203, 304, 307, 308, 9xx).

As a rule, this refers to an external wiring fault.

B.) Alarm relay (relay contact terminals 12+13+14):

This relay is set at the factory as follows:

- **DE-ENERGIZED** in operating states A.1 and A.2 but energized if a "START" signal is present in one of these states.
- **ENERGIZED** in operating state A.3.

If the alarm relay has the opposite configuration to the factory setting (↪ section 5.2.3 "Configuration of the rotary coding switches for device names" on page 13), these states are reversed.

C.) Error code indicated via the PROFINET protocol:

If an error occurs, the "AL" bit is set and possibly also the "WA" bit. The error code is contained in the third word at bit positions 0...9 (↪ section 6.6.12 "Error codes" on page 24).

D.) Error code indicated via the actual value output 0...10 VDC (terminals 17+18):

Since a temperature indication is no longer necessary if a fault occurs, the actual value output is used to display error messages whenever a fault is signaled.

Thirteen voltage levels are available for this purpose in the 0...10 VDC range, each of which is assigned an error code (↪ section 6.19 "Error messages" on page 36).

If a state that requires AUTOCAL occurs – or if the device configuration is incorrect – (error codes 104...106, 111...114, 211, 302, 303), the signal at the actual value output jumps back and forth at 1 Hz between the voltage value corresponding to the error and the end of the scale (10 VDC, i.e. 300°C or 500°C). If the "START" signal is present in one of these states, the voltage value does not change any more.

If a ROPEX temperature meter (e.g. an ATR-x) is connected to the controller's analog output, the temperature indication can be directly assigned to the error codes if an alarm is signaled.

An error message can be reset by setting the "RS" bit or by momentarily interrupting the power to the controller (24 VDC supply voltage).

If an error message is reset with the "RS" bit, it is not actually reset until the "RS" bit is reset.

Invalid error messages may appear when the controller is switched off owing to the undefined operating state. This must be taken into account when they are evaluated by the higher-level controller (e.g. a PLC) in order to avoid false alarms.

6.19 Error messages

In addition to the error codes diagnosed in the event protocol, you can also access the PROFINET diagnosis function (extended device diagnosis). The error codes appear in the configuring tool in plain text because they are stored in the device master file (GSDML).

The table below shows the meaning of the error codes. It includes a description of each error as well as the required corrective action.

The block diagram in section 6.20 "Fault areas and causes" on page 40 helps you clear a particular error quickly and efficiently.

Thirteen voltage levels for diagnosing errors appear at the controller's actual value output. The error messages are even more finely differentiated internally. The 3-digit error codes described below can be displayed via the PROFINET interface or in the ROPEX visualization software (↪ section 6.12 "USB interface for visualization software (ROPEXvisual®)" on page 34) to facilitate troubleshooting).

 If the actual value output is evaluated in order to identify an error message – in the higher-level controller, for instance – the tolerance window must be adjusted to prevent incorrect

interpretations. Please note the tolerances of the actual value output (↪ section 8 "Technical data" on page 43).

Part 1 of 3: Error messages (faults)

NOTE: The error messages shown here are output as faults (constant error voltage at actual value output, alarm LED lit continuously, alarm relay energized).

Error code	Act. val. output voltage [V]	Cause	Action if machine started for first time	Action if machine already operated, HS band not changed
101	0.66	No current signal	Fault area ①	Fault area ①
102	1.33	No voltage signal	Fault area ③	Fault area ③
103	2.00	No current / voltage signals	Fault area ②	Fault areas ②⑨
107	2.66	Temperature step, down	Fault areas ④⑤⑥ ("loose contact")	Fault areas ④⑤⑥ ("loose contact")
108		Temperature step, up		
307		Temperature too high / low (↪ section 6.7.10)	-	-
308				
309				
310				
201	3.33	No line frequency / line frequency fluctuates	Check power supply	Check power supply
202		Line frequency too high / fluctuates		
203		Line frequency too low / fluctuates		
304	4.00	Heatup time too long (↪ section 6.7.11)	Perform RESET	Perform RESET
901	4.66	No line voltage / sync signal	↪ Section 6.2	↪ Section 6.2
913		Triac defective	Replace device	Replace device
914		Internal fault, device defective	Replace device	Replace device
915				
916				
917	Jumper for alarm output incorrect	Check jumper	Check jumper	
918				

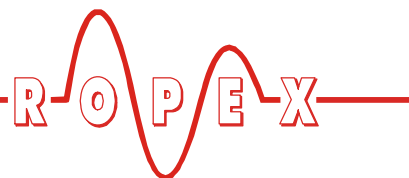

Part 2 of 3: Error messages (warnings)

NOTE: The specified error messages are initially output as warnings (actual value output jumps back and forth between two values, alarm LED blinks, alarm relay de-energized). When the "START" signal is activated, the warning changes to a fault (actual value output no longer jumps back and forth, see bold italic values, alarm LED lit continuously, alarm relay energized).

Error code	Act. val. output voltage [V]	Cause	Action if machine started for first time	Action if machine already operated, HS band not changed
104	↔ 5.33 ↔ ↔ 10 ↔	Current signal incorrect, incorrect impulse transformer specification	Perform AUTOCAL , check transformer specification, fault areas ⑦ ⑧	Fault areas ④ ⑤ ⑥ ("loose contact")
105		Voltage signal incorrect, incorrect impulse transformer specification		
106		Current and voltage signals incorrect, incorrect impulse transformer specification		
302		Temperature too low, calibration not performed, loose contact, ambient temp. fluctuates	Perform AUTOCAL and / or	
303		Temperature too high, calibration not performed, loose contact, ambient temp. fluctuates	fault areas ④ ⑤ ⑥ ("loose contact")	
211	↔ 6.00 ↔ ↔ 10 ↔	Data error	Perform AUTOCAL	Perform AUTOCAL

Part 3 of 3: Error messages (warnings)

NOTE: The specified error messages are initially output as warnings (actual value output jumps back and forth between two values, alarm LED blinks, alarm relay de-energized). When the "START" signal is activated, the warning changes to a fault (actual value output no longer jumps back and forth, see bold italic values, alarm LED lit continuously, alarm relay energized).

Error code	Act. val. output voltage [V]	Cause	Action if machine started for first time	Action if machine already operated, HS band not changed
111	<i>↔ 6.66 ↔</i> ↔ 10 ↔	Current signal incorrect, no calibration possible	Fault area ⑧, check configuration	Fault areas ④ ⑤ ⑥ ("loose contact")
112	<i>↔ 7.33 ↔</i> ↔ 10 ↔	Voltage signal incorrect, no calibration possible	Fault area ⑦, check configuration	Fault areas ④ ⑤ ⑥ ("loose contact")
113	<i>↔ 8.00 ↔</i> ↔ 10 ↔	Current / voltage signals incorrect, no calibration possible	Fault area ⑦ ⑧, check configuration	Fault areas ④ ⑤ ⑥ ("loose contact")
114		Temperature fluctuates, no calibration possible	Perform AUTOCAL and / or fault areas ④ ⑤ ⑥ ("loose contact")	Perform AUTOCAL and / or fault areas ④ ⑤ ⑥ ("loose contact")
115	<i>↔ 8.66 ↔</i> ↔ 10 ↔	Ext. calibration temp. too high, no calibration possible	Perform AUTOCAL with ext. calibration temperature ≤40°C	Perform AUTOCAL with ext. calibration temperature ≤40°C
116		Ext. calibration temp. fluctuates, no calibration possible	Perform AUTOCAL with stable ext. calibration temperature	Perform AUTOCAL with stable ext. calibration temperature

6.20 Fault areas and causes

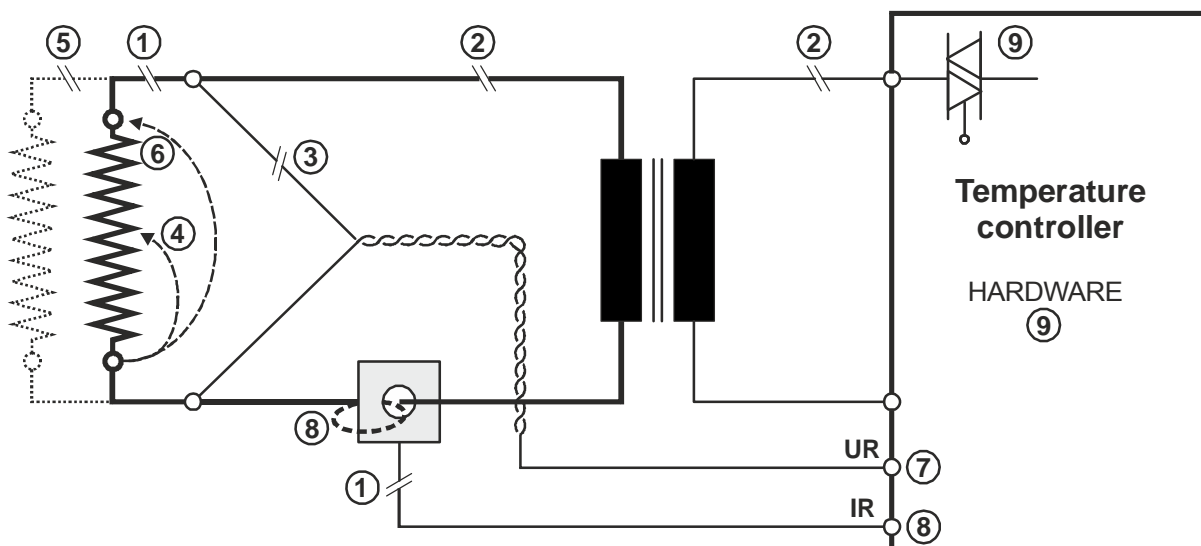





The table below explains the possible fault causes.

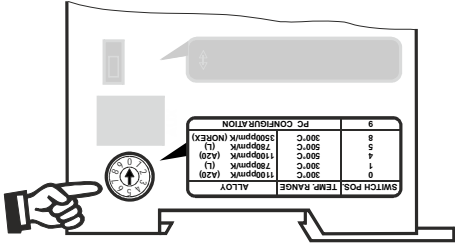
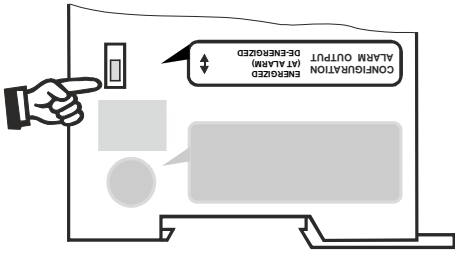

Fault area	Explanation	Possible causes
①	Load circuit interrupted after U_R pickoff point	- Wire break, heatsealing band break - Contact to heatsealing band is defective
	PEX-W2/-W3/-W4 current transformer signal interrupted	- I_R measurement cable from current transformer interrupted
②	Primary circuit interrupted	- Wire break, triac in controller defective - Primary winding of impulse transformer interrupted - Kb contactor open
	Secondary circuit interrupted before U_R pickoff point	- Wire break - Secondary winding of impulse transformer interrupted
③	No U_R signal	- Measurement cable interrupted
④	Partial short-circuit (ΔR)	- Heatsealing band partially bypassed by conducting part (clamp, opposite heatsealing bar etc.)
⑤	Parallel circuit interrupted	- Wire break, heatsealing band break - Contact to heatsealing band is defective
⑥	Total short-circuit	- Heatsealing band incorrectly installed, no insulation at heatsealing bar ends or insulation incorrectly installed - Heatsealing band completely bypassed by conducting part
⑦	U_R signal incorrect	- U_2 outside of permissible range from 0.4...120 VAC
⑧	I_R signal incorrect	- I_2 outside of permissible range from 30...500 A
	Wire incorrectly laid through PEX-W2/-W3/-W4 current transformer	- Check number of turns (two or more turns required for currents < 30 A)
⑨	Internal device fault / no line voltage	- Hardware fault (replace controller) - Jumper for alarm relay not connected or incorrectly connected - No line voltage



7 Factory settings

The RESISTRON[®] RES-5010 temperature controller is configured at the factory as follows:

<p><u>Rotary coding switch</u> for heatsealing band alloy and temperature range</p>	 <table border="1" data-bbox="662 555 885 645"> <thead> <tr> <th>SWITCH POS.</th> <th>TEMP RANGE</th> <th>ALLOY</th> </tr> </thead> <tbody> <tr> <td>0</td> <td>300°C</td> <td>1100pmk (A20)</td> </tr> <tr> <td>1</td> <td>300°C</td> <td>1100pmk (L)</td> </tr> <tr> <td>4</td> <td>500°C</td> <td>1100pmk (A20)</td> </tr> <tr> <td>5</td> <td>500°C</td> <td>1100pmk (L)</td> </tr> <tr> <td>8</td> <td>300°C</td> <td>1100pmk (A20)</td> </tr> <tr> <td>9</td> <td>300°C</td> <td>1100pmk (L)</td> </tr> </tbody> </table>	SWITCH POS.	TEMP RANGE	ALLOY	0	300°C	1100pmk (A20)	1	300°C	1100pmk (L)	4	500°C	1100pmk (A20)	5	500°C	1100pmk (L)	8	300°C	1100pmk (A20)	9	300°C	1100pmk (L)	<p>Heatsealing band alloy: Alloy 20 Temperature range: 300°C</p> <p>Rotary coding switch: "0" position</p>
SWITCH POS.	TEMP RANGE	ALLOY																					
0	300°C	1100pmk (A20)																					
1	300°C	1100pmk (L)																					
4	500°C	1100pmk (A20)																					
5	500°C	1100pmk (L)																					
8	300°C	1100pmk (A20)																					
9	300°C	1100pmk (L)																					
<p><u>Slide switch</u> for alarm relay</p>		<p>Alarm relay energized at alarm</p>																					
<p><u>Automatic phase angle compensation</u> (AUTOCOMP)</p>		<p>AUTOCOMP: Off</p>																					
<p><u>Temperature diagnosis</u></p>		<p>Temperature diagnosis: Off</p>																					
<p><u>Heatup timeout</u></p>		<p>Heatup timeout: Off</p>																					

8 Technical data

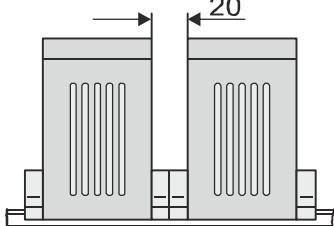
Type of construction	Housing for installation in an electrical cabinet Snaps onto a standard top hat rail (TS35 rail, 35 mm) acc. to DIN EN 50022 Dimensions: 90 x 75 mm; height: 135 mm (incl. terminals)
Line voltage	110 VAC -15%...300 VAC +10% (equivalent to 94...330 VAC) Connected between neutral conductor and one line conductor or 110 VAC -15%...415 VAC +10% (equivalent to 94...456 VAC) Connected between two line conductors  The voltage between the line conductor and ground must not be more than 300 VAC.
Power supply system	Balanced TN or TT system, max. 415 VAC Installation category III  Operation in potential-free systems (e.g. an IT system) is only permitted after consultation with ROPEX.
Line frequency	47...63 Hz, automatic adjustment to frequencies in this range
Current consumption (primary current of impulse transformer)	$I_{\max} = 5 \text{ A}$ (duty cycle = 100%) $I_{\max} = 25 \text{ A}$ (duty cycle = 20%, cycle duration 1 min)
24 VDC supply voltage Terminals 5+7	24 VDC, $I_{\max} = 200 \text{ mA}$ Tolerance: $\pm 10\%$ SELV or PELV supplied from max. 300 VAC, Cat II
Measuring range	Secondary voltage U_R : 0.4...120 VAC Secondary current I_R : 30...500 A (with PEX-W2/-W3/-W4 current transformer) ↳ ROPEX Application Report
PROFINET interface	"Conformance Class C", IO / RT and IRT acc. to IEC 61784-2 2 Ethernet switch ports RJ45 Wiring: IEC 61784-5-3 Data transfer rate: 100 Mbit/s Data transport layer: Ethernet II, IEEE 802.3 Topology discovery: LLDP, SNMP V1, MIB2, physical device Addressing: DCP or selectable with rotary coding switch FSU (Fast Startup) support: Yes, but startup time approx. 1.5 s.

Heatsealing band type and temperature range	<p>The temperature range and temperature coefficient settings can also be specified in the ROPEX visualization software (↪ section 6.12 "USB interface for visualization software (ROPEXvisual®)" on page 34) in addition to using the rotary coding switch or via the PROFINET interface (see below):</p> <p>Temperature range: 200°C, 300°C, 400°C, or 500°C Temperature coefficient: 400...4000 ppm/K (variable setting range)</p> <p>Five different ranges can be set using the rotary coding switch or via the PROFINET interface:</p> <p>Temperature coefficient 1100 ppm/K, 0...300°C (e.g. Alloy 20) Temperature coefficient 780 ppm/K, 0...300°C (e.g. Alloy L) Temperature coefficient 1100 ppm/K, 0...500°C (e.g. Alloy A20) Temperature coefficient 780 ppm/K, 0...500°C (e.g. Alloy L) Temperature coefficient 3500 ppm/K, 0...300°C (e.g. NOREX)</p>
Analog output (actual value) Terminals 17+18	0...10 VDC, $I_{max} = 5 \text{ mA}$ Equivalent to 0...300°C or 0...500°C Accuracy: $\pm 1\%$ plus 50 mV
Alarm relay Terminals 12, 13, 14	$U_{max} = 30 \text{ V (DC/AC)}$, $I_{max} = 0.2 \text{ A}$, changeover contact, potential-free
Power loss	Max. 20 W
Ambient conditions	Max. altitude: 2000 m Ambient temperature: +5...+45°C Max. relative humidity: 80% at temperatures up to +31°C, decreasing linearly to 50% relative humidity at +45°C
Degree of protection	IP20
UL file	E464680
Installation	<p>A minimum safety clearance of 20 mm all round (e.g. from other devices and wiring) must be allowed when installing the device.</p> <p>The moving clip required for fastening must be facing down for mounting on a horizontal top hat rail.</p> <p>End holders to mechanically fix the controller must be fitted at both ends for mounting on a vertical top hat rail.</p> 
Weight	Approx. 0.5 kg (incl. connector plug-in parts)
Housing material	Plastic, polycarbonate, UL-94-V0
Connecting cable Type / cross-sections	<p>Rigid or flexible; 0.2...2.5 mm² (AWG 24...12) Plug-in connectors</p> <p>Plug-in connectors: Tightening torque: 0.5...0.6 Nm (screwdriver: SZS 0.6x3.5 mm)</p> <p> If ferrules are used, they must be crimped in accordance with DIN 46228 and IEC / EN 60947-1. This is essential to ensure proper electrical contact in the terminals.</p>

9 Dimensions

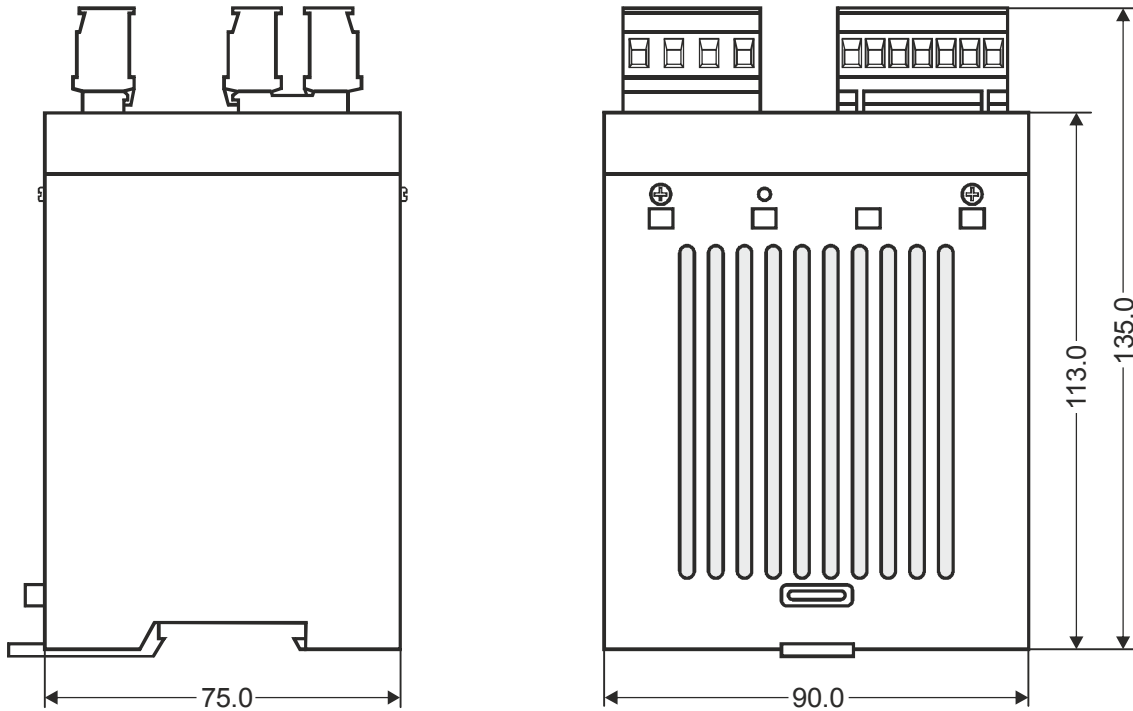



10 Accessories and modifications

A wide range of compatible accessories and peripheral devices are available for the RESISTRON RES-5010 temperature controller. We would be pleased to prepare an Application Report for you free of charge. They allow it to be optimally adapted to your specific heatsealing application as well as to the design and operating philosophy of your system.

10.1 Accessories

The products described below are only a few of the wide range of accessories available for RESISTRON temperature controllers.

	<p>Analog temperature meter ATR-x For front panel mounting or mounting on a top hat rail (DIN TS35 rail). Analog indication of the ACTUAL heatsealing band temperature in °C. The meter damping of the unit is optimized for the abrupt temperature changes that occur in impulse mode.</p>
	<p>Line filter LF-xx480 Essential to ensure CE conformity. Optimized for RESISTRON temperature controllers.</p>

	<p>Impulse transformer TR-x Designed according to VDE 0570 / EN 61558 with a one-section bobbin. Optimized for impulse operation with RESISTRON temperature controllers. Specified according to the heatsealing application (↪ ROPEX Application Report).</p>
	<p>Booster External switching amplifier, necessary for high primary currents (continuous current > 5 A, pulsed current > 25 A)</p>
	<p>Current transformer PEX-W3/W4 Essential for measuring the secondary current. The PEX-W4 current transformer also has UL approval.</p>
	<p>Monitoring current transformer MSW For detecting frame short-circuits at the heatsealing band. Used as an alternative to the standard PEX-W2/-W3/-W4 current transformer.</p>
	<p>U_R measurement cable UML-1 Twisted cable for measuring the U_R voltage. Suitable for drag chains; contains neither halogens nor silicone.</p>

10.2 Modifications (MODs)







Owing to its universal design, the RESISTRON RES-5010 temperature controller is suitable for a very wide range of heatsealing applications.

One modification (MOD) is available for the RESISTRON RES-5010 temperature controller for implementing special applications.

MOD 01

Booster for low secondary voltages ($U_R = 0.2 \dots 60 \text{ VAC}$). This modification is necessary, for example, for very short or low-resistance heatsealing bands.

11 How to order

	<p>Controller RES - 5010 Power supply 115...400 VAC, Art. No. 7501000 Scope of supply: Controller includes connector plug-in parts (without current transformer)</p> <p>Modification MOD . . (optional, if required) e.g. → 01: MOD 01, Art. No. 800001 (booster for low voltage)</p> <p>Please indicate the article numbers of the controller and the required modifications (optional) in all orders, e.g. RES-5010 + MOD 01 (controller with booster for low voltage) Art Nos. 7501000 + 800001 must be ordered</p>
	<p>Current transformer PEX-W . → PEX-W3: Art. No. 885105 → PEX-W4: Art. No. 885106</p>
	<p>Line filter LF- . . 480 → 06: Continuous current 6 A, 480 VAC, Art. No. 885500 → 35: Continuous current 35 A, 480 VAC, Art. No. 885506</p>
	<p>Impulse transformer See ROPEX Application Report for design and ordering information</p>
	<p>Temperature meter ATR - . → 3: 300°C range, Art. No. 882130 → 5: 500°C range, Art. No. 882150</p>
	<p>Booster B- . . . → 075400: Max. pulse load 75 A, 400 VAC, Art. No. 885301 → 075415: Max. pulse load 75 A, 415 VAC, Art. No. 885302 → 100400: Max. pulse load 100 A, 400 VAC, Art. No. 885304</p>

12 Index

Numbers

24VDC supply voltage 43

A

"AA" bit 23
 "AC" bit 21
 Actual value 24
 Actual value output 33
 "AG" bit 23
 "AL" bit 15, 23
 Alarm output 36
 Alarm relay 14, 44
 Alloy 13, 16
 Altitude 44
 Ambient conditions 44
 Ambient temperature 44
 Analog temperature meter 45
 Application 4
 Application Report 6, 9
 AUTOCAL 15
 Active 23
 Blocked 21, 23
 Starting 21
 AUTOCOMP 28
 Automatic phase angle compensation 28
 Automatic zero calibration 15, 21
 AUX interface 35

B

Booster 11, 46, 47
 Booster connection 34
 Burning in (heatsealing band) 14, 16

C

Circuit-breaker 8
 Control active 24
 Current transformer 9, 47

D

Data format 28
 Data memory 35
 Date 35
 Degree of protection 44
 Device master file (GSDML) 19
 Dimensions 45

E

Error code format 28
 Error messages 36
 External module/channel errors 28
 External switching amplifier 11, 46

F

Factory settings 42
 Fault 23
 Fault areas 40
 Fuse 8

H

Heatsealing band type 44
 Heatup timeout 30

I

Impulse heatsealing method 4
 Impulse transformer 8, 46, 47
 Input data 20
 Installation 6, 44
 Installation procedure 6
 Installation regulations 6

L

Line filter 8, 9, 45, 47
 Line frequency 43
 Line voltage 43, 47

M

Maintenance 43
 Master AUTOCAL (MA) 22
 Measurement cable 46
 Measurement pause 22
 Measuring impulse duration 28
 Measuring range 43
 Modification MOD 46, 47
 "MP" bit 22

O

Output data 23
 Over-current protection 8

P

PEX-W2/-W3 3
 PEX-W3 9, 47
 PEX-W4 9
 Phase angle compensation 28
 Power loss 44
 Power supply 8
 Power supply system 43
 PROFINET interface 43

R

"RA" bit 15, 24
 Relative humidity 44
 Replacement (heatsealing band) 14, 16
 Reset 22

ROPEXvisual 34
"RS" bit 22

S

Set point 23
Standby mode 33
Start 21
"START" bit 15
Startup 12
System diagnosis 34
System monitoring 36

T

TCR 3, 14
"TE" bit 23
Temperature achieved 23
Temperature coefficient 3, 14
Temperature control 4
Temperature diagnosis 29, 30
Temperature meter 34, 45, 47
Temperature OK 23

Temperature range 13, 44
Time 35
Timestamp 35
"TO" bit 23
Transformer 3, 8, 46, 47
Type of construction 43

U

UL file 44
USB interface 34

V

View of the device 12
Visualization software 34

W

Web server 31
Wiring 6, 8
Wiring diagram 10, 11